

ETP HYDRO-GRIP®

HSK Form A - DIN 69893

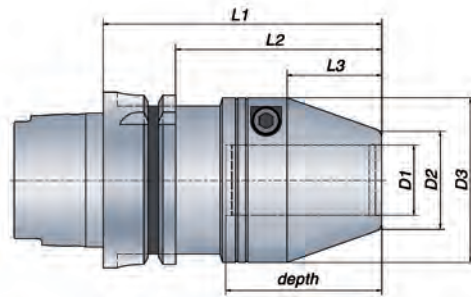

Metric range

Technical Specification HSK form A

HSK size	Part no.	Item description	Dimensions, mm										
			D1	D2	D3	L1	L2	L3	depth	T* Nm	Weight kg	G 2.5 at rpm	
●	63	685630	HG-12/HSK63A	12	22	43.5	76	50	18	40	60 - 125	1.1	25 000
●		685640	HG-12x100/HSK63A	12	22	43.5	100	74	18	40	60 - 125	1.4	25 000
○		685650	HG-16/HSK63A	16	26	48	86	60	28	50	165 - 270	1.2	25 000
○		685660	HG-16x125/HSK63A	16	20	48	125	99	28	50	165 - 270	1.8	25 000
●		685670	HG-20/HSK63A	20	30	52	88	62	30	52	260 - 425	1.3	25 000
●		685680	HG-20x150/HSK63A	20	30	52	150	124	30	52	260 - 425	2.3	25 000
●		685690	HG-25/HSK63A	25	35	59	100	74	34	56	480 - 710	1.6	25 000
●		685700	HG-25x150/HSK63A	25	35	59	150	124	34	56	480 - 710	2.7	25 000
●		685710	HG-32/HSK63A	32	42	69.5	105	79	38	60	820 - 1250	2.0	25 000
●	100	685720	HG-12/HSK100A	12	22	43.5	79	50	18	40	60 - 125	2.4	14 000
●		685730	HG-12x100/HSK100A	12	22	43.5	100	71	18	40	60 - 125	2.7	14 000
○		685740	HG-16/HSK100A	16	26	48	89	60	28	50	165 - 270	2.6	14 000
○		685750	HG-16x125/HSK100A	16	26	48	125	96	28	50	165 - 270	3.1	14 000
●		685760	HG-20/HSK100A	20	30	52	91	62	30	52	260 - 425	2.7	14 000
●		685770	HG-20x150/HSK100A	20	30	52	150	121	30	52	260 - 425	3.6	14 000
●		685780	HG-25/HSK100A	25	35	59	95	66	34	56	480 - 710	2.9	14 000
●		685790	HG-25x150/HSK100A	25	35	59	150	121	34	56	480 - 710	4.0	14 000
●		685800	HG-32/HSK100A	32	42	69.5	99	70	38	60	820 - 1250	3.3	14 000

Inch range

Technical Specification HSK form A

HSK size	Part no.	Item description	Dimensions, inch										
			D1	D2	D3	L1	L2	L3	depth	T* ft·lb	Weight kg	G 2.5 at rpm	
●	63	685630-T	HG-1/2"/HSK63A	0.500	0.866	1.713	2.992	1.969	0.709	1.575	55 - 105	1.1	25 000
○		685640-T	HG-1/2"x100/HSK63A	0.500	0.866	1.713	3.937	2.913	0.709	1.575	55 - 105	1.4	25 000
●		685670-T	HG-3/4"/HSK63A	0.750	1.181	2.047	3.465	2.441	1.181	2.047	192 - 314	1.3	25 000
●		685680-T	HG-3/4"x150/HSK63A	0.750	1.181	2.047	5.906	4.882	1.181	2.047	192 - 314	2.3	25 000
●		685690-T	HG-1"/HSK63A	1.000	1.378	2.323	3.937	2.913	1.339	2.205	354 - 524	1.6	25 000
○		685700-T	HG-1"x150/HSK63A	1.000	1.378	2.323	5.906	4.882	1.339	2.205	354 - 524	2.7	25 000
●		685710-T	HG-1 1/4"/HSK63A	1.250	1.654	2.736	4.134	3.110	1.496	2.362	605 - 922	2.0	25 000
○	100	685720-T	HG-1/2"/HSK100A	0.500	0.866	1.713	3.110	1.969	0.709	1.575	55 - 105	2.4	14 000
●		685730-T	HG-1/2"x100/HSK100A	0.500	0.866	1.713	3.937	2.795	0.709	1.575	55 - 105	2.7	14 000
●		685760-T	HG-3/4"/HSK100A	0.750	1.181	2.047	3.583	2.441	1.181	2.047	192 - 314	2.7	14 000
●		685770-T	HG-3/4"x150/HSK100A	0.750	1.181	2.047	5.906	4.764	1.181	2.047	192 - 314	3.6	14 000
●		685780-T	HG-1"/HSK100A	1.000	1.378	2.323	3.740	2.598	1.339	2.205	354 - 524	2.9	14 000
●		685790-T	HG-1"x150/HSK100A	1.000	1.378	2.323	5.906	4.764	1.339	2.205	354 - 524	4.0	14 000
●		685800-T	HG-1 1/4"/HSK100A	1.250	1.654	2.736	3.898	2.756	1.496	2.362	605 - 922	3.3	14 000

*) T = Min. and Max. transmittable torque using a h6 cylindrical tool, full depth insert. For additional information see section Technical Information.

- From stock
- On request

Information:

- Runout accuracy < 0.004 mm at 2.5 x D1 (max. 50 mm)
≤ 0.00016 inch at 2.5x D1 (max. 1.969 inch)
- Tool shank h6 or h7 can be used
- Center thread, M8x1.25, for axial length adjustment screw (screw not included)
- Coolant through on all holders
- Bore for data carrier

Accessories:

Use preset Torque Wrench, 6 Nm, to ensure correct mounting of tools. Part no. 19050

ETP HYDRO-GRIP can be used with reducing sleeves. For additional information see section Accessories.



ETP HYDRO-GRIP®

HSK Form C - DIN 69893

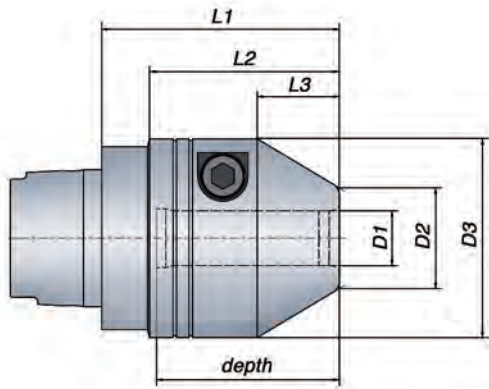

Metric range

Technical Specification HSK form C

HSK size	Part no.	Item description	Dimensions, mm									
			D1	D2	D3	L1	L2	L3	depth	T* Nm	Weight kg	G 2.5 at rpm
● 32	705667	HG-12/HSK32C	12	22	43.5	52	40.5	18	40	60-125	0.4	25 000
● 40	705668	HG-12/HSK40C	12	22	43.5	52	41.5	18	40	60-125	0.5	25 000
○	705673	HG-20/HSK40C	20	30	52	64	52.4	30	52	260 - 425	0.7	25 000
● 50	705716	HG-20/HSK50C	20	30	52	67	54.5	30	52	260-425	0.8	25 000

Inch range

Technical Specification HSK form C

HSK size	Part no.	Item description	Dimensions, inch									
			D1	D2	D3	L1	L2	L3	depth	T* ft-lb	Weight kg	G 2.5 at rpm
○ 40	706094	HG-1"/HSK40C	1.000	1.378	2.323	2.835	2.343	1.339	2.205	354 - 524	0.9	25 000
○ 50	705695	HG-1"/HSK50C	1.000	1.378	2.323	2.795	2.303	1.339	2.205	354 - 524	1.0	25 000

*) T = Min. and Max. transmittable torque using a h6 cylindrical tool, full depth insert. For additional information see section Technical Information.

● From stock

○ On request

Information:

- Runout accuracy ≤ 0.004 mm at $2.5 \times D1$ (max. 50 mm)
 ≤ 0.00016 inch at $2.5 \times D1$ (max. 1.969 inch)
- Tool shank h6 or h7 can be used
- Center thread, M8x1.25, for axial length adjustment screw (screw not included)
- Coolant through on all holders
- Bore for data carrier

Accessories:

Use preset Torque Wrench, 6 Nm, to ensure correct mounting of tools. Part no. 19050.

ETP HYDRO-GRIP can be used with reducing sleeves.

For additional information see section Accessories.



ETP HYDRO-GRIP®

HSK Form C - For HYDROMAT® Rotary transfer machines

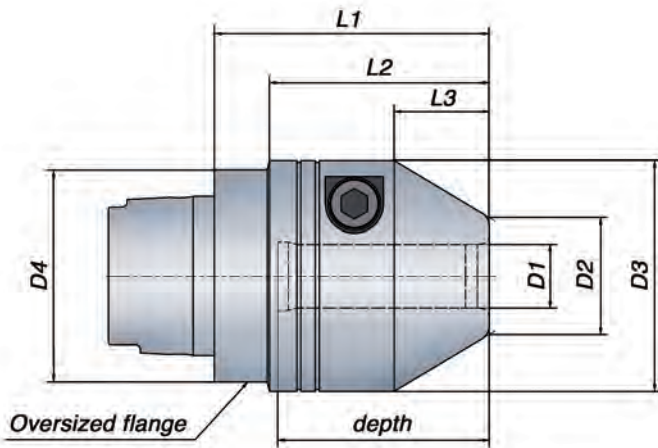

Metric range

Technical Specification HSK form C			Dimensions, mm											
HSK size	Part no.	Item description	D1	D2	D3	D4	L1	L2	L3	depth	T* Nm	Weight kg	G 2.5 at rpm	
<input type="radio"/>	32	705727	HG-12/HSK32C - HM40	12	22	43.5	40	52	41.5	18	40	60-125	0.4	25 000
<input checked="" type="radio"/>	40	705728	HG-20/HSK40C - HM50	20	30	52	50	64	53.7	30	52	260-425	0.7	25 000
<input type="radio"/>	50	705729	HG-32/HSK50C - HM63	32	42	69.5	63	85	64.1	38	60	820-1250	1.6	25 000

*) T = Min. and Max. transmittable torque using a h6 cylindrical tool, full depth insert. For additional information see section Technical Information.

- From stock
- On request

Information:

- Runout accuracy ≤ 0.004 mm at $2.5 \times D1$ (max. 50 mm)
 ≤ 0.00016 inch at $2.5 \times D1$ (max. 1.969 inch)
- Tool shank h6 or h7 can be used
- Center thread, M8x1.25, for axial length adjustment screw (screw not included)
- Coolant through on all holders
- Bore for data carrier

Accessories:

Use preset Torque Wrench, 6 Nm, to ensure correct mounting of tools. Part no. 19050.

ETP HYDRO-GRIP can be used with reducing sleeves.
For additional information see section Accessories.



ETP HYDRO-GRIP®

ISO Form AD/B - 7388-1

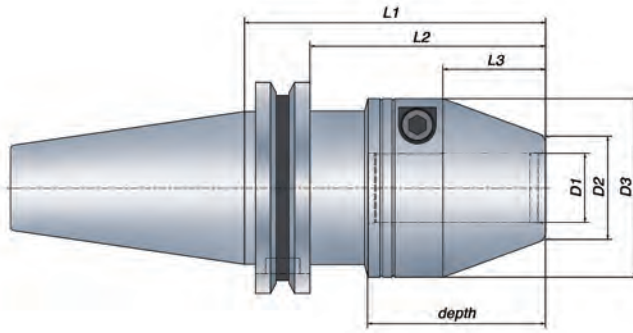

Metric range

Technical Specification ISO form AD/B

Taper	Part no.	Item description	Dimensions, mm										
			D1	D2	D3	L1	L2	L3	depth	T* Nm	Weight kg	G 2.5 at rpm	
●	685810	HG-12/ISO40	12	22	43.5	56	36.9	18	40	60-125	1.1	25 000	
	685820	HG-12x100/ISO40	12	22	43.5	100	80.9	18	40	60-125	1.6	25 000	
	○	685830	HG-16/ISO40	16	26	48	73	53.9	28	50	165-270	1.3	25 000
	○	685840	HG-16x125/ISO40	16	26	48	125	105.9	28	50	165-270	2.1	25 000
	●	685850	HG-20/ISO40	20	30	52	88	68.9	30	52	260-425	1.6	25 000
	●	685860	HG-20x125/ISO40	20	30	52	125	105.9	30	52	260-425	2.2	25 000
	●	685870	HG-25/ISO40	25	35	59	93	73.9	34	56	480-710	1.7	25 000
○	685880	HG-12/ISO50	12	22	43.5	56	36.9	18	40	60-125	2.9	14 000	
	685890	HG-12x100/ISO50	12	22	43.5	100	80.9	18	40	60-125	3.4	14 000	
	685900	HG-16/ISO50	16	26	48	66	46.9	28	50	165-270	3.1	14 000	
	685910	HG-16x125/ISO50	16	26	48	125	105.9	28	50	165-270	3.9	14 000	
	●	685920	HG-20/ISO50	20	30	52	68	48.9	30	52	260-425	3.1	14 000
	●	685930	HG-20x150/ISO50	20	30	52	150	130.9	30	52	260-425	4.5	14 000
	●	685940	HG-25/ISO50	25	35	59	72	52.9	34	56	480-710	3.3	14 000
	●	685950	HG-25x150/ISO50	25	35	59	150	130.9	34	56	480-710	4.9	14 000
	●	685960	HG-32/ISO50	32	42	69.5	77	57.9	38	60	820-1250	3.6	14 000

Inch range

Technical Specification ISO form AD/B

Taper	Part no.	Item description	Dimensions, inch									
			D1	D2	D3	L1	L2	L3	depth	T* ft-lb	Weight kg	G 2.5 at rpm
○	685810-T	HG-1/2"/ISO40	0.500	0.866	1.713	2.205	1.453	0.709	1.575	55-105	1.1	25 000
	685820-T	HG-1/2"x100/ISO40	0.500	0.866	1.713	3.937	3.185	0.709	1.575	55-105	1.6	25 000
	685850-T	HG-3/4"/ISO40	0.750	1.181	2.047	3.465	2.713	1.181	2.047	192-314	1.6	25 000
	685860-T	HG-3/4"x125/ISO40	0.750	1.181	2.047	4.921	4.169	1.181	2.047	192-314	2.2	25 000
	685870-T	HG-1"/ISO40	1.000	1.378	2.323	3.661	2.909	1.339	2.205	354-524	1.7	25 000
○	685920-T	HG-3/4"/ISO50	0.750	1.181	2.047	2.677	1.925	1.181	2.047	192-314	3.1	14 000
	685930-T	HG-3/4"x150/ISO50	0.750	1.181	2.047	5.906	5.154	1.181	2.047	192-314	4.5	14 000
	685940-T	HG-1"/ISO50	1.000	1.378	2.323	2.835	2.083	1.339	2.205	354-524	3.3	14 000
	685950-T	HG-1"x150/ISO50	1.000	1.378	2.323	5.906	5.154	1.339	2.205	354-524	4.9	14 000
○	685960-T	HG-1 1/4"/ISO50	1.250	1.654	2.736	3.031	2.280	1.496	2.362	605-922	3.6	14 000

*) T = Min. and Max. transmittable torque using a h6 cylindrical tool, full depth insert. For additional information see section Technical Information.

- From stock
- On request

Information:

- Runout accuracy < 0.004 mm at 2.5 x D1 (max. 50 mm) ≤ 0.00016 inch at 2.5x D1 (max. 1.969 inch)
- Tool shank h6 or h7 can be used
- Center thread, M8x1.25, for axial length adjustment screw (screw not included)
- Coolant through on all holders
- Bore for data carrier

Accessories:

Use preset Torque Wrench, 6 Nm, to ensure correct mounting of tools. Part no. 19050

ETP HYDRO-GRIP can be used with reducing sleeves. For additional information see section Accessories.



ETP HYDRO-GRIP®

BT Form AD - JIS B 6339

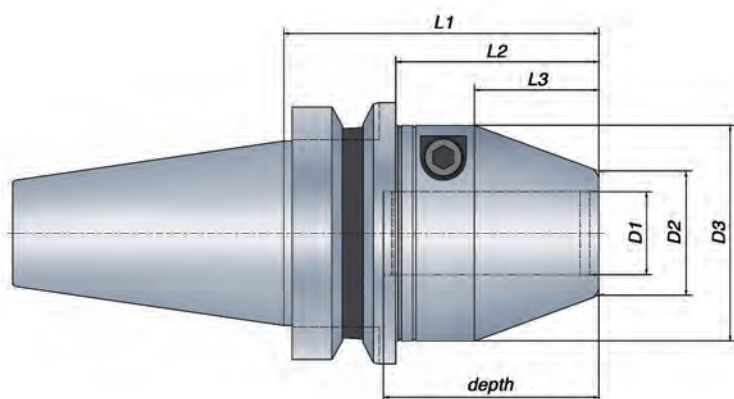

Metric range

Technical Specification BT form AD

Taper	Part no.	Item description	Dimensions, mm										
			D1	D2	D3	L1	L2	L3	depth	T* Nm	Weight kg	G 2.5 at rpm	
●	30	685970	HG-12/BT30	12	22	43.5	59	37	18	40	60-125	0.7	25 000
○		685980	HG-16/BT30	16	26	48	69	47	28	50	165-270	1	25 000
●		685991	HG-20/BT30	20	30	52	89	54	30	52	260-425	1.1	25 000

Inch range

Technical Specification BT form AD

Taper	Part no.	Item description	Dimensions, inch										
			D1	D2	D3	L1	L2	L3	depth	T* ft-lb	Weight kg	G 2.5 at rpm	
●	30	685970-T	HG-1/2"/BT30	0.500	0.866	1.713	2.323	1.457	0.709	1.575	55-105	0.7	25 000
●		685991-T	HG-3/4"/BT30	0.750	1.181	2.047	3.504	2.126	1.181	2.047	192-314	1.1	25 000

*) T = Min. and Max. transmittable torque using a h6 cylindrical tool, full depth insert. For additional information see section Technical Information.

- From stock
- On request

Information:

- Runout accuracy < 0.004 mm at 2.5 x D1 (max. 50 mm)
≤ 0.00016 inch at 2.5x D1 (max. 1.969 inch)
- Tool shank h6 or h7 can be used
- Center thread, M8x1.25, for axial length adjustment screw (screw not included)
- Coolant through on all holders
- Bore for data carrier - available on request

Accessories:

Use preset Torque Wrench, 6 Nm, to ensure correct mounting of tools. Part no. 19050

ETP HYDRO-GRIP can be used with reducing sleeves. For additional information see section Accessories.



ETP HYDRO-GRIP®

BT Form AD/B - JIS B 6339

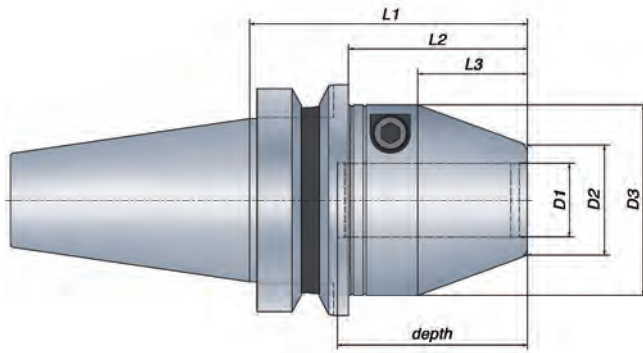

Metric range

Technical Specification BT form AD/B

Taper	Part no.	Item description	Dimensions, mm									
			D1	D2	D3	L1	L2	L3	depth	T* Nm	Weight kg	G 2.5 at rpm
40	685000	HG-12/BT40	12	22	43.5	64	37	18	40	60-125	1.3	25 000
	685010	HG-12x100/BT40	12	22	43.5	100	73	18	40	60-125	1.7	25 000
	685020	HG-16/BT40	16	26	48	74	47	28	50	165-270	1.4	25 000
	685030	HG-16x125/BT40	16	26	48	125	98	28	50	165-270	1.9	25 000
	685040	HG-20/BT40	20	30	52	76	49	30	52	260-425	1.5	25 000
	685050	HG-20x125/BT40	20	30	52	125	98	30	52	260-425	2.3	25 000
50	685060	HG-25/BT40	25	35	59	80	53	34	56	480-710	1.6	25 000
	685070	HG-12/BT50	12	22	43.5	75	37	18	40	60-125	3.9	14 000
	685080	HG-12x100/BT50	12	22	43.5	100	62	18	40	60-125	4.3	14 000
	685090	HG-16/BT50	16	26	48	85	47	28	50	165-270	4.1	14 000
	685100	HG-16x125/BT50	16	26	48	125	87	28	50	165-270	4.6	14 000
	685110	HG-20/BT50	20	30	52	87	49	30	52	260-425	4.1	14 000
	685120	HG-20x150/BT50	20	30	52	150	112	30	52	260-425	5.2	14 000
	685130	HG-25/BT50	25	35	59	91	53	34	56	480-710	4.3	14 000
	685140	HG-25x150/BT50	25	35	59	150	112	34	56	480-710	5.5	14 000
	685150	HG-32/BT50	32	42	69.5	95	57	38	60	820-1250	4.5	14 000

Inch range

Technical Specification BT form AD/B

Taper	Part no.	Item description	Dimensions, inch									
			D1	D2	D3	L1	L2	L3	depth	T* ft-lb	Weight kg	G 2.5 at rpm
40	685000-T	HG-1/2"/BT40	0.500	0.866	1.713	2.520	1.457	0.709	1.575	55-105	1.3	25 000
	685010-T	HG-1/2"x100/BT40	0.500	0.866	1.713	3.937	2.874	0.709	1.575	55-105	1.7	25 000
	685040-T	HG-3/4"/BT40	0.750	1.181	2.047	2.992	1.929	1.181	2.047	192-314	1.5	25 000
	685050-T	HG-3/4"x125/BT40	0.750	1.181	2.047	4.921	3.858	1.181	2.047	192-314	2.3	25 000
	685060-T	HG-1"/BT40	1.000	1.378	2.323	3.150	2.087	1.339	2.205	354-524	1.6	25 000
50	685110-T	HG-3/4"/BT50	0.750	1.181	2.047	3.425	1.929	1.181	2.047	192-314	4.1	14 000
	685120-T	HG-3/4"x150/BT50	0.750	1.181	2.047	5.906	4.409	1.181	2.047	192-314	5.2	14 000
	685130-T	HG-1"/BT50	1.000	1.378	2.323	3.583	2.087	1.339	2.205	354-524	4.3	14 000
	685140-T	HG-1"x150/BT50	1.000	1.378	2.323	5.906	4.409	1.339	2.205	354-524	5.5	14 000
	685150-T	HG-1 1/4"/BT50	1.250	1.654	2.736	3.740	2.244	1.496	2.362	605-922	4.5	14 000

*) T = Min. and Max. transmittable torque using a h6 cylindrical tool, full depth insert. For additional information see section Technical Information.

- From stock
- On request

Information:

- Runout accuracy ≤ 0.004 mm at 2.5 x D1 (max. 50 mm), ≤ 0.00016 inch at 2.5x D1 (max. 1.969 inch)
- Tool shank h6 or h7 can be used
- Center thread, M8x1.25, for axial length adjustment screw (screw not included)
- Coolant through on all holders
- Bore for data carrier

Accessories:

Use preset Torque Wrench, 6 Nm, to ensure correct mounting of tools. Part no. 19050.

ETP HYDRO-GRIP can be used with reducing sleeves. For additional information see section Accessories.



ETP HYDRO-GRIP® CAT Form AD/B - ASME B5.50

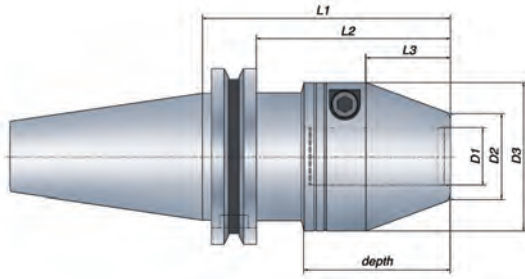

Metric range

Technical Specification CAT form AD/B														
Taper	Part no.	Item description	Dimensions, mm									T* Nm	Weight kg	G 2.5 at rpm
			D1	D2	D3	L1	L2	L3	depth					
●	40	685470	HG-12/CAT40	12	22	43.5	56	36.95	18	40	60-125	1.1	25 000	
●		685480	HG-12x100/CAT40	12	22	43.5	100	80.95	18	40	60-125	1.6	25 000	
○		685490	HG-16/CAT40	16	26	48	86	66.95	28	50	165-270	1.5	25 000	
○		685500	HG-16x125/CAT40	16	26	48	125	105.95	28	50	165-270	2	25 000	
●		685510	HG-20/CAT40	20	30	52	88	68.95	30	52	260-425	1.5	25 000	
●		685520	HG-20x125/CAT40	20	30	52	125	105.95	30	52	260-425	2.1	25 000	
●		685530	HG-25/CAT40	25	35	59	93	73.95	34	56	480-710	1.7	25 000	
●		705911	HG-32/CAT40	32	42	69.5	104	84.95	38	60	820 - 1250	2.2	25 000	
○	50	685540	HG-12/CAT50	12	22	43.5	56	36.95	18	40	60-125	2.8	14 000	
○		685550	HG-12x100/CAT50	12	22	43.5	100	80.95	18	40	60-125	3.2	14 000	
○		685560	HG-16/CAT50	16	26	48	66	46.95	28	50	165-270	3	14 000	
○		685570	HG-16x125/CAT50	16	26	48	125	105.95	28	50	165-270	3.5	14 000	
●		685580	HG-20/CAT50	20	30	52	68	48.95	30	52	260-425	3	14 000	
●		685590	HG-20x150/CAT50	20	30	52	150	130.95	30	52	260-425	4.4	14 000	
●		685600	HG-25/CAT50	25	35	59	72	52.95	34	56	480-710	3.2	14 000	
●		685610	HG-25x150/CAT50	25	35	59	150	130.95	34	56	480-710	4.8	14 000	
●		685620	HG-32/CAT50	32	42	69.5	77	57.95	38	60	820-1250	3.5	14 000	

Inch range

Technical Specification CAT form AD/B														
Taper	Part no.	Item description	Dimensions, inch									T* ft-lb	Weight kg	G 2.5 at rpm
			D1	D2	D3	L1	L2	L3	depth					
●	40	685470-T	HG-1/2"/CAT40	0.500	0.866	1.713	2.205	1.455	0.709	1.575	55-105	1.1	25 000	
○		685480-T	HG-1/2"x100/CAT40	0.500	0.866	1.713	3.937	3.187	0.709	1.575	55-105	1.6	25 000	
●		685510-T	HG-3/4"/CAT40	0.750	1.181	2.047	3.465	2.715	1.181	2.047	192-314	1.5	25 000	
●		682410-T	HG-3/4"x4"/CAT40	0.750	1.181	2.047	4.000	3.250	1.181	2.047	192-314	2.1	25 000	
●		685520-T	HG-3/4"x125/CAT40	0.750	1.181	2.047	4.921	4.171	1.181	2.047	192-314	2.1	25 000	
●		682420-T	HG-3/4"x6"/CAT40	0.750	1.181	2.047	6.000	5.250	1.181	2.047	192-314	2.6	25 000	
●		685530-T	HG-1"/CAT40	1.000	1.378	2.323	3.661	2.911	1.339	2.205	354-524	1.7	25 000	
●		705911-T	HG-1 1/4"/CAT40	1.250	1.654	2.736	4.094	3.344	1.496	2.362	605 - 922	2.2	25 000	
●	50	685580-T	HG-3/4"/CAT50	0.750	1.181	2.047	2.677	1.927	1.181	2.047	192-314	3	14 000	
●		682460-T	HG-3/4"x4"/CAT50	0.750	1.181	2.047	4.000	3.250	1.181	2.047	192-314	3.6	14 000	
●		682470-T	HG-3/4"x6"/CAT50	0.750	1.181	2.047	6.000	5.250	1.181	2.047	192-314	4.4	14 000	
●		685600-T	HG-1"/CAT50	1.000	1.378	2.323	2.835	2.085	1.339	2.205	354-524	3.2	14 000	
●		682480-T	HG-1"x4"/CAT50	1.000	1.378	2.323	4.000	3.250	1.339	2.205	354-524	3.8	14 000	
●		682490-T	HG-1"x6"/CAT50	1.000	1.378	2.323	6.000	5.250	1.339	2.205	354-524	4.9	14 000	
●		685620-T	HG-1 1/4"/CAT50	1.250	1.654	2.736	3.031	2.281	1.496	2.362	605-922	3.5	14 000	

*) T = Min. and Max. transmittable torque using a h6 cylindrical tool, full depth insert. For additional information see section Technical Information.

- From stock
- On request

Information:

- Runout accuracy ≤ 0.004 mm at $2.5 \times D1$ (max. 50 mm), ≤ 0.00016 inch at $2.5 \times D1$ (max. 1.969 inch)
- Tool shank h6 or h7 can be used
- Center thread, M8x1.25, for axial length adjustment screw (screw not included)
- Coolant through on all holders
- Bore for data carrier

Accessories:

Use correct Torque Wrench, 6 Nm, to ensure correct mounting of tools. Part no. 19050.

ETP HYDRO-GRIP can be used with reducing sleeves. For additional information see section Accessories.



ETP HYDRO-GRIP®

CAT Form AD/B - ASME B5.50 Dual Contact

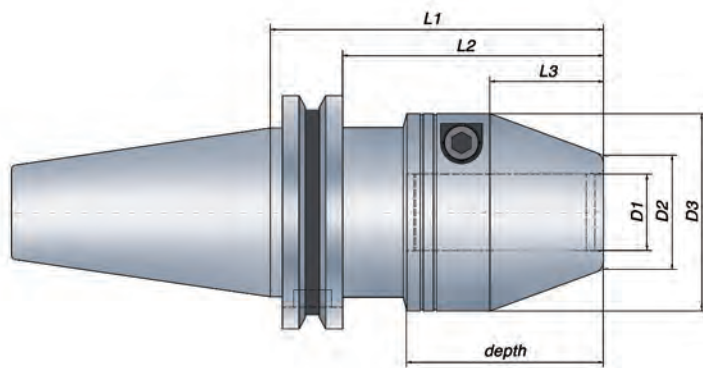

Metric range

Technical Specification CAT form AD/B Dual Contact

Taper	Part no.	Item description	Dimensions, mm										
			D1	D2	D3	L1	L2	L3	depth	T* Nm	Weight kg	G 2.5 at rpm	
40	681480	HG-20/DC-CAT40	20	30	52	88	68.95	30	52	260 - 425	1.5	25 000	

*) T = Min. and Max. transmittable torque using a h6 cylindrical tool, full depth insert. For additional information see section Technical Information.

Inch range

Technical Specification CAT form AD/B Dual Contact

Taper	Part no.	Item description	Dimensions, inch										
			D1	D2	D3	L1	L2	L3	depth	T* ft·lb	Weight kg	G 2.5 at rpm	
40	681480-T	HG-3/4"/DC-CAT40	0.750	1.181	2.047	3.465	2.715	1.181	2.047	192 - 314	1.5	25 000	

*) T = Min. and Max. transmittable torque using a h6 cylindrical tool, full depth insert. For additional information see section Technical Information.

- From stock
- On request

Information:

- Runout accuracy ≤ 0.004 mm at $2.5 \times D1$ (max. 50 mm),
 ≤ 0.00016 inch at $2.5 \times D1$ (max. 1.969 inch)
- Tool shank h6 or h7 can be used
- Center thread, M8x1.25, for axial length adjustment screw (screw not included)
- Coolant through on all holders
- Bore for data carrier

Accessories:

Use preset Torque Wrench, 6 Nm, to ensure correct mounting of tools. Part no. 19050.

ETP HYDRO-GRIP can be used with reducing sleeves.
For additional information see section Accessories.



ETP HYDRO-GRIP®

PSK Form - ISO 26623-1

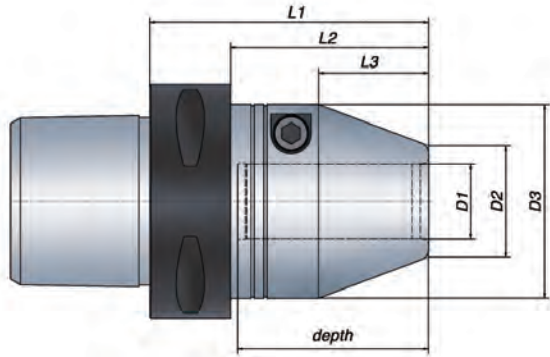

Metric range

Technical Specification PSK form															
Coupling size	Part no.	Item description	Dimensions, mm										T* Nm	Weight kg	G 2.5 at rpm
			D1	D2	D3	L1	L2	L3	depth						
● **)	C3	701558	HG-12/C3 (no gripper)	12	22	43.5	50	43	18	40	60-125	0.4	25 000		
● **)	C4	703430	HG-12/C4 (no gripper)	12	22	43.5	50	43	18	40	60-125	0.5	25 000		
●	C4	685160	HG-12/C4	12	22	43.5	62	43	18	40	60-125	0.6	25 000		
●		685170	HG-12x100/C4	12	22	43.5	100	80	18	40	60-125	1	25 000		
○		685180	HG-16/C4	16	26	48	72	52	28	50	165-270	0.7	25 000		
○		685190	HG-16x125/C4	16	26	48	125	105	28	50	165-270	1.2	25 000		
●		685200	HG-20/C4	20	30	52	75	55	30	52	260-425	0.8	25 000		
●		685210	HG-20x125/C4	20	30	52	125	105	30	52	260-425	1.6	25 000		
●	C5	685220	HG-12/C5	12	22	43.5	62	42	18	40	60-125	0.8	25 000		
●		685230	HG-12x100/C5	12	22	43.5	100	80	18	40	60-125	1.2	25 000		
○		685240	HG-16/C5	16	26	48	72	52	28	50	165-270	1	25 000		
○		685250	HG-16x125/C5	16	26	48	125	105	28	50	165-270	1.5	25 000		
●		685260	HG-20/C5	20	30	52	74	54	30	52	260-425	1	25 000		
●		685270	HG-20x125/C5	20	30	52	125	105	30	52	260-425	1.8	25 000		
●		685280	HG-25/C5	25	35	59	79	59	34	56	480-710	1.2	25 000		

Inch range

Technical Specification PSK form															
Coupling size	Part no.	Item description	Dimensions, inch										T* ft-lb	Weight kg	G 2.5 at rpm
			D1	D2	D3	L1	L2	L3	depth						
●	C4	685200-T	HG-3/4"/C4	0.750	1.181	2.047	2.953	2.165	1.181	2.047	192-314	0.8	25 000		
●	C5	685280-T	HG-1"/C5	1.000	1.378	2.323	3.110	2.323	1.339	2.205	354-524	1.2	25 000		

*) T = Min. and Max transmittable torque using a h6 cylindrical tool, full depth insert. For additional information see section Technical Information.

Additional PSK Inch equivalents add " -T" to metric part no. Available on request.

**) Short version with no gripper grooves.

- From stock
- On request

Information:

- Runout accuracy ≤ 0.004 mm at $2.5 \times D1$ (max. 50 mm), ≤ 0.00016 inch at $2.5 \times D1$ (max. 1.969 inch)
- Tool shank h6 or h7 can be used
- Center thread, M8x1.25, for axial length adjustment screw (screw not included)
- Coolant through on all holders
- Bore for data carrier

Accessories:

Use preset Torque Wrench, 6 Nm, to ensure correct mounting of tools. Part no. 19050.

ETP HYDRO-GRIP can be used with reducing sleeves.

For additional information see section Accessories.



ETP HYDRO-GRIP®

PSK Form - ISO 26623-1

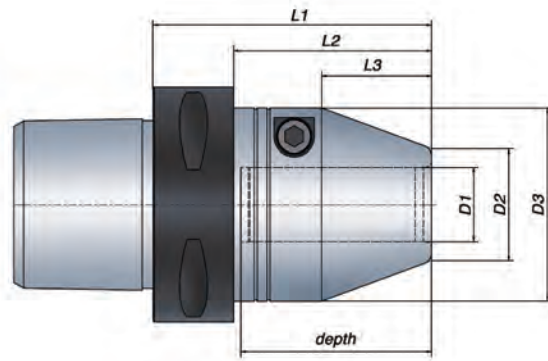

Metric range

Technical Specification PSK form

Coupling size	Part no.	Item description	Dimensions, mm										G 2.5 at rpm
			D1	D2	D3	L1	L2	L3	depth	T* Nm	Weight kg		
●	685290	HG-12/C6	12	22	43.5	64	42	18	40	60-125	1.1	25 000	
	685300	HG-12x100/C6	12	22	43.5	100	78	18	40	60-125	1.5	25 000	
	685310	HG-16/C6	16	26	48	74	52	28	50	165-270	1.2	25 000	
	685320	HG-16x125/C6	16	26	48	125	103	28	50	165-270	1.7	25 000	
	685330	HG-20/C6	20	30	52	76	54	30	52	260-425	1.3	25 000	
	685340	HG-20x150/C6	20	30	52	150	128	30	52	260-425	2.5	25 000	
	685350	HG-25/C6	25	35	59	80	58	34	56	480-710	1.5	25 000	
	685360	HG-25x150/C6	25	35	59	150	128	34	56	480-710	3	25 000	
	685370	HG-32/C6	32	42	69.5	84	62	38	60	820-1250	1.8	25 000	
	○	685380	HG-12/C8	12	22	43.5	67	37	18	40	60-125	2.1	14 000
685390		HG-12x100/C8	12	22	43.5	100	70	18	40	60-125	2.5	14 000	
685400		HG-16/C8	16	26	48	77	47	28	50	165-270	2.2	14 000	
685410		HG-16x125/C8	16	26	48	125	95	28	50	165-270	2.7	14 000	
685420		HG-20/C8	20	30	52	79	49	30	52	260-425	2.3	14 000	
685430		HG-20x150/C8	20	30	52	150	120	30	52	260-425	3.4	14 000	
685440		HG-25/C8	25	35	59	83	53	34	56	480-710	2.4	14 000	
685450		HG-25x150/C8	25	35	59	150	120	34	56	480-710	3.8	14 000	
●	685460	HG-32/C8	32	42	69.5	87	57	38	60	820-1250	2.7	14 000	

Inch range

Technical Specification PSK form

Coupling size	Part no.	Item description	Dimensions, inch										G 2.5 at rpm
			D1	D2	D3	L1	L2	L3	depth	T* Nm	Weight kg		
●	685290-T	HG-1/2"/C6	0.500	0.866	1.713	2.520	1.654	0.709	1.575	55-105	1.1	25 000	
	685330-T	HG-3/4"/C6	0.750	1.181	2.047	2.992	2.126	1.181	2.047	192-314	1.3	25 000	
	685350-T	HG-1"/C6	1.000	1.378	2.323	3.150	2.283	1.339	2.205	354-524	1.5	25 000	

*) T = Min. and Max transmittable torque using a h6 cylindrical tool, full depth insert. For additional information see section Technical Information.

Additional PSK Inch equivalents add "-T" to metric part no. Available on request.

- From stock
- On request

Information:

- Runout accuracy ≤ 0.004 mm at $2.5 \times D1$ (max. 50 mm), ≤ 0.00016 inch at $2.5 \times D1$ (max. 1.969 inch)
- Tool shank h6 or h7 can be used
- Center thread, M8x1.25, for axial length adjustment screw (screw not included)
- Coolant through on all holders
- Bore for data carrier

Accessories:

Use preset Torque Wrench, 6 Nm, to ensure correct mounting of tools. Part no. 19050.

ETP HYDRO-GRIP can be used with reducing sleeves. For additional information see section Accessories.

