

ETP HYDRO-GRIP® PENCIL HSK Form A - DIN 69893

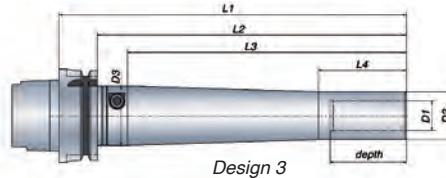
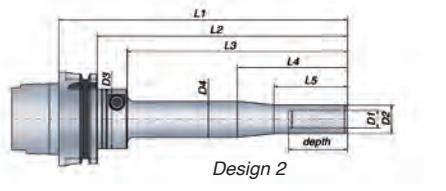
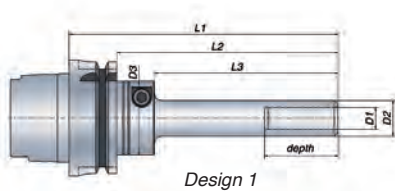

Metric range

Technical Specification HSK form A

Design	HSK size	Part no.	Item description	Dimensions, mm											T* Nm	Weight kg	G 2.5 at rpm		
				D1	D2	D3	D4	L1	L2	L3	L4	L5	depth						
●	1	63	683810	HG PENCIL-6x50/HSK63A	6	12	40		96.5	70.5	50					40	12-22	0.9	25 000
○	1		683740	HG PENCIL-8x50/HSK63A	8	14.5	40		96.5	70.5	50					40	27-40	0.9	25 000
○	1		683760	HG PENCIL-10x50/HSK63A	10	17	40		96.5	70.5	50					40	35-70	0.9	25 000
○	1		683750	HG PENCIL-10x100/HSK63A	10	17	40		146.5	120.5	100					40	35-70	1.0	15 000
●	1		683830	HG PENCIL-12x50/HSK63A	12	19.5	40		96.5	70.5	50					40	60-125	0.9	25 000
●	1		683840	HG PENCIL-12x100/HSK63A	12	19.5	40		146.5	120.5	100					40	60-125	1.0	15 000
●	2		683820	HG PENCIL-12x150/HSK63A	12	19.5	40	24.5	196.5	170.5	150	75	50		40	60-125	1.2	10 000	
○	1		683780	HG PENCIL-16x75/HSK63A	16	26	40		121.5	95.5	75					50	165-270	1.1	15 000
○	1		683770	HG PENCIL-16x125/HSK63A	16	26	40		171.5	145.5	125					50	165-270	1.3	10 000
●	3		683790	HG PENCIL-20x110/HSK63A	20	32	40		156.5	130.5	110	60				52	260-425	1.5	20 000
●	3		683800	HG PENCIL-20x190/HSK63A	20	32	40		236.5	210.5	190	60				52	260-425	2.1	10 000
○	1	100	683860	HG PENCIL-10x50/HSK100A	10	17	40		117	88	50					40	35-70	2.4	14 000
●	1		683850	HG PENCIL-10x100/HSK100A	10	17	40		167	138	100					40	35-70	2.5	14 000
●	1		683890	HG PENCIL-12x50/HSK100A	12	19.5	40		117	88	50					40	60-125	2.4	14 000
●	1		683920	HG PENCIL-12x100/HSK100A	12	19.5	40		167	138	100					40	60-125	2.5	14 000
●	2		683930	HG PENCIL-12x150/HSK100A	12	19.5	40	24.5	217	188	150	75	50		40	60-125	2.7	10 000	
○	1		683880	HG PENCIL-16x75/HSK100A	16	26	40		142	113	75					50	165-270	2.6	14 000
○	1		683870	HG PENCIL-16x125/HSK100A	16	26	40		192	163	125					50	165-270	2.8	10 000
●	3		683900	HG PENCIL-20x110/HSK100A	20	32	40		177	148	110	60				52	260-425	3.0	14 000
●	3		683910	HG PENCIL-20x190/HSK100A	20	32	40		257	228	190	60				52	260-425	3.6	10 000

Inch range

Technical Specification HSK form A

Design	HSK size	Part no.	Item description	Dimensions, inch											T* ft·lb	Weight kg	G 2.5 at rpm		
				D1	D2	D3	D4	L1	L2	L3	L4	L5	depth						
●	1	63	683810-T	HG PENCIL-1/4"x50/HSK63A	0.250	0.472	1.575		3.799	2.776	1.969					1.575	13-20	0.9	25 000
●	1		683830-T	HG PENCIL-1/2"x50/HSK63A	0.500	0.768	1.575		3.799	2.776	1.969					1.575	55-105	0.9	25 000
●	1		683840-T	HG PENCIL-1/2"x100/HSK63A	0.500	0.768	1.575		5.768	4.744	3.937					1.575	55-105	1.0	15 000
●	2		683820-T	HG PENCIL-1/2"x150/HSK63A	0.500	0.768	1.575	0.965	7.736	6.713	5.906	2.953	1.969		1.575	55-105	1.2	10 000	
●	3		683790-T	HG PENCIL-3/4"x110/HSK63A	0.750	1.260	1.575		6.161	5.138	4.331	2.362				2.047	192-314	1.5	20 000
●	3		683800-T	HG PENCIL-3/4"x190/HSK63A	0.750	1.260	1.575		9.311	8.287	7.480	2.362				2.047	192-314	2.1	10 000
●	1	100	683890-T	HG PENCIL-1/2"x50/HSK100A	0.500	0.768	1.575		4.606	3.465	1.969					1.575	55-105	2.4	14 000
●	1		683920-T	HG PENCIL-1/2"x100/HSK100A	0.500	0.768	1.575		6.575	5.433	3.937					1.575	55-105	2.5	14 000
●	2		683930-T	HG PENCIL-1/2"x150/HSK100A	0.500	0.768	1.575	0.965	8.543	7.402	5.906	2.953	1.969		1.575	55-105	2.7	10 000	
●	3		683900-T	HG PENCIL-3/4"x110/HSK100A	0.750	1.260	1.575		6.969	5.827	4.331	2.362				2.047	192-314	3.0	14 000
●	3		683910-T	HG PENCIL-3/4"x190/HSK100A	0.750	1.260	1.575		10.118	8.976	7.480	2.362				2.047	192-314	3.6	10 000

*) T = Min. and Max. transmittable torque using a h6 cylindrical tool, full depth insert. For additional information see section Technical Information.

- From stock
- On request

Information:

- Runout accuracy < 0.004 mm at 2.5 x D1 (max. 50 mm)
 ≤ 0.00016 inch at 2.5 x D1 (max. 1.969 inch)
 ≤ 0.007 mm at 2.5 x D1 at length L1 > 125 mm
 ≤ 0.00028 inch at 2.5 x D1 at length L1 > 4.921 inch
- Tool shank h6 or h7 can be used
- Coolant through on all holders
- Bore for data carrier

Accessories:

Use preset Torque Wrench, 6 Nm, to ensure correct mounting of tools. Part no. 19050

ETP HYDRO-GRIP PENCIL can be used with reducing sleeves.

For additional information see section Accessories.



ETP HYDRO-GRIP® PENCIL HSK Form F - DIN 69893

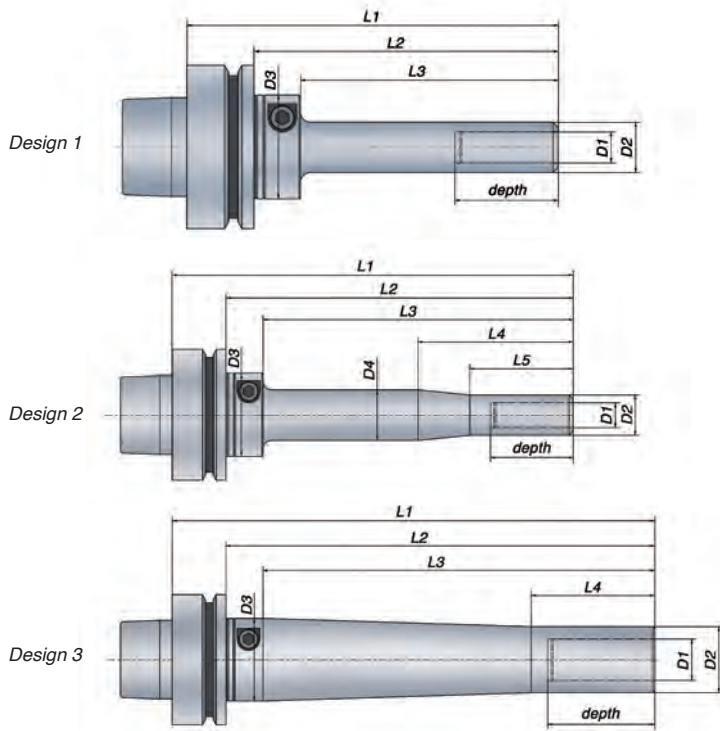

Metric range

Technical Specification HSK form F

Design	HSK size	Part no.	Item description	Dimensions, mm													
				D1	D2	D3	D4	L1	L2	L3	L4	L5	depth	T* Nm	Weight kg	G 2.5 at rpm	
● 1	63	684400	HG PENCIL-6x50/HSK63F	6	12	40		94	68	50				40	12-22	0.8	25 000
● 1		684440	HG PENCIL-12x50/HSK63F	12	19.5	40		94	68	50				40	60-125	0.9	25 000
● 1		684450	HG PENCIL-12x100/HSK63F	12	19.5	40		144	118	100				40	60-125	1	15 000
● 2		684460	HG PENCIL-12x150/HSK63F	12	19.5	40	24.5	194	168	150	75	50	40	60-125	1.2	10 000	
● 3		684490	HG PENCIL-20x110/HSK63F	20	32	40		154	128	110	60		52	260-425	1.4	20 000	
● 3		684500	HG PENCIL-20x190/HSK63F	20	32	40		234	208	190	60		52	260-425	2.1	10 000	

Inch range

Technical Specification HSK form F

Design	HSK size	Part no.	Item description	Dimensions, inch													
				D1	D2	D3	D4	L1	L2	L3	L4	L5	depth	T* ft-lb	Weight kg	G 2.5 at rpm	
● 1	63	684540	HG PENCIL-1/2"x50/HSK63F	0.500	0.768	1.575		3.701	2.677	1.969				1.575	55-105	0.9	25 000
● 1		684550	HG PENCIL-1/2"x100/HSK63F	0.500	0.768	1.575		5.669	4.646	3.937				1.575	55-105	1	15 000
● 2		684560	HG PENCIL-1/2"x150/HSK63F	0.500	0.768	1.575	0.965	7.638	6.614	5.906	2.953	1.969	1.575	55-105	1.2	10 000	
● 3		684590	HG PENCIL-3/4"x110/HSK63F	0.750	1.260	1.575		6.063	5.039	4.331	2.362		2.047	192-314	1.4	20 000	
● 3		684600	HG PENCIL-3/4"x190/HSK63F	0.750	1.260	1.575		9.213	8.189	7.480	2.362		2.047	192-314	2.1	10 000	

*) T = Min. and Max. transmittable torque using a h6 cylindrical tool, full depth insert. For additional information see section Technical Information.

- From stock
- On request

Information:

- Runout accuracy < 0.004 mm at 2.5 x D1 (max. 50 mm)
 ≤ 0.00016 inch at 2.5x D1 (max. 1.969 inch)
 ≤ 0.007 mm at 2.5 x D1 at length L1 > 125 mm
 ≤ 0.00028 inch at 2.5x D1 at length L1 > 4.921 inch
- Tool shank h6 or h7 can be used
- Coolant through on all holders

Accessories:

Use preset Torque Wrench, 6 Nm, to ensure correct mounting of tools. Part no. 19050

ETP HYDRO-GRIP PENCIL can be used with reducing sleeves.

For additional information see section Accessories.



ETP HYDRO-GRIP® PENCIL ISO Form AD/B - 7388-1

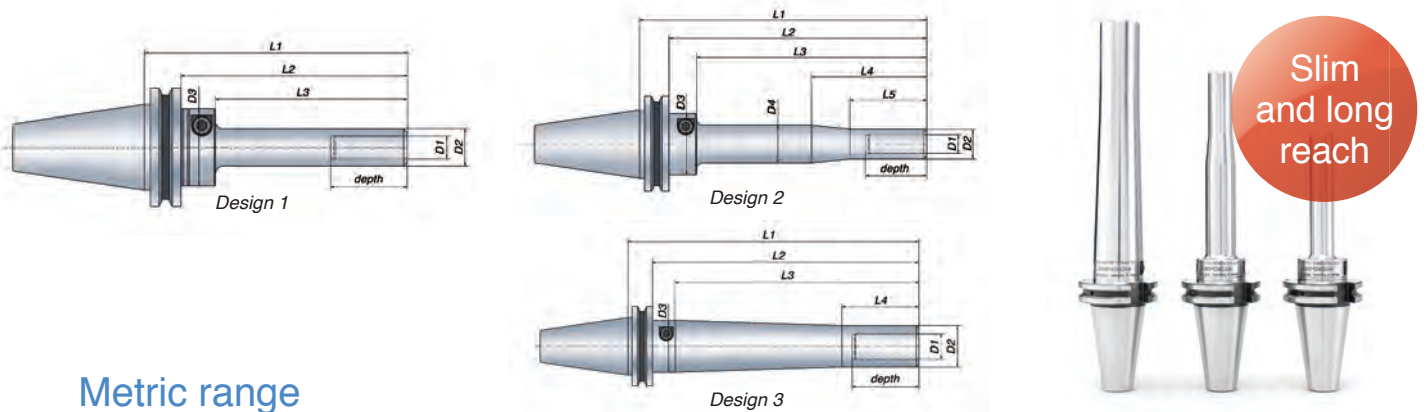

Metric range

Technical Specification ISO form AD/B

Design	Taper	Part no.	Item description	Dimensions, mm											T* Nm	Weight kg	G 2.5 at rpm	
				D1	D2	D3	D4	L1	L2	L3	L4	L5	depth					
● 1	40	683940	HG PENCIL-6x50/ISO40	6	12	40		87	67.9	50					40	12-22	1	25 000
○ 1		683950	HG PENCIL-8x50/ISO40	8	14.5	40		87	67.9	50					40	27-40	1	25 000
○ 1		683970	HG PENCIL-10x50/ISO40	10	17	40		87	67.9	50					40	35-70	1	25 000
○ 1		683960	HG PENCIL-10x100/ISO40	10	17	40		137	117.9	100					40	35-70	1.1	15 000
● 1		684000	HG PENCIL-12x50/ISO40	12	19.5	40		87	67.9	50					40	60-125	1.1	25 000
● 1		684010	HG PENCIL-12x100/ISO40	12	19.5	40		137	117.9	100					40	60-125	1.2	15 000
● 2		684030	HG PENCIL-12x150/ISO40	12	19.5	40	24.5	187	167.9	150	75	50		40	60-125	1.4	10 000	
○ 1		683990	HG PENCIL-16x75/ISO40	16	26	40		112	92.9	75				50	165-270	1.2	15 000	
○ 1		683980	HG PENCIL-16x125/ISO40	16	26	40		162	142.9	125				50	165-270	1.4	10 000	
● 3		684020	HG PENCIL-20x110/ISO40	20	32	40		147	127.9	110	60			52	260-425	1.6	20 000	
● 3		684040	HG PENCIL-20x190/ISO40	20	32	40		227	207.9	190	60			52	260-425	2.3	10 000	
● 1	50	684190	HG PENCIL 12x50/ISO50	12	19.5	40		87	67.9	50				40	60-125	2.9	14 000	
● 1		684200	HG PENCIL 12x100/ISO50	12	19.5	40		137	117.9	100				40	60-125	3	14 000	
● 2		684210	HG PENCIL 12x150/ISO50	12	19.5	40	24.5	187	167.9	150	75	50		40	60-125	3.2	10 000	
● 3		684240	HG PENCIL 20x110/ISO50	20	32	40		147	127.9	110	60			52	260-425	3.4	14 000	
● 3		684250	HG PENCIL 20x190/ISO50	20	32	40		227	207.9	190	60			52	260-425	4.1	10 000	

Inch range

Technical Specification ISO form AD/B

Design	Taper	Part no.	Item description	Dimensions, inch											T* ft-lb	Weight kg	G 2.5 at rpm	
				D1	D2	D3	D4	L1	L2	L3	L4	L5	depth					
○ 1	40	683940-T	HG PENCIL-1/4"x50/ISO40	0.250	0.472	1.575		3.425	2.673	1.969					1.575	13-20	1	25 000
○ 1		684000-T	HG PENCIL-1/2"x50/ISO40	0.500	0.768	1.575		3.425	2.673	1.969					1.575	55-105	1.1	25 000
○ 1		684010-T	HG PENCIL-1/2"x100/ISO40	0.500	0.768	1.575		5.394	4.642	3.937					1.575	55-105	1.2	15 000
○ 2		684030-T	HG PENCIL-1/2"x150/ISO40	0.500	0.768	1.575	0.965	7.362	6.610	5.906	2.953	1.969		1.575	55-105	1.4	10 000	
○ 3		684020-T	HG PENCIL-3/4"x110/ISO40	0.750	1.260	1.575		5.787	5.035	4.331	2.362			2.047	192-314	1.6	20 000	
○ 3		684040-T	HG PENCIL-3/4"x190/ISO40	0.750	1.260	1.575		8.937	8.185	7.480	2.362			2.047	192-314	2.3	10 000	
○ 1	50	684190-T	HG PENCIL 1/2"x50/ISO50	0.500	0.768	1.575		3.425	2.673	1.969				1.575	55-105	2.9	14 000	
○ 1		684200-T	HG PENCIL 1/2"x100/ISO50	0.500	0.768	1.575		5.394	4.642	3.937				1.575	55-105	3	14 000	
○ 2		684210-T	HG PENCIL 1/2"x150/ISO50	0.500	0.768	1.575	0.965	7.362	6.610	5.906	2.953	1.969		1.575	55-105	3.2	10 000	
○ 3		684240-T	HG PENCIL 3/4"x110/ISO50	0.750	1.260	1.575		5.787	5.035	4.331	2.362			2.047	192-314	3.4	14 000	
○ 3		684250-T	HG PENCIL 3/4"x190/ISO50	0.750	1.260	1.575		8.937	8.185	7.480	2.362			2.047	192-314	4.1	10 000	

*) T = Min. and Max. transmittable torque using a h6 cylindrical tool, full depth insert. For additional information see section Technical Information.

- From stock
- On request

Information:

- Runout accuracy ≤ 0.004 mm at $2.5 \times D1$ (max. 50 mm)
 ≤ 0.00016 inch at $2.5 \times D1$ (max. 1.969 inch)
- ≤ 0.007 mm at $2.5 \times D1$ at length $L1 > 125$ mm
- ≤ 0.00028 inch at $2.5 \times D1$ at length $L1 > 4.921$ inch
- Tool shank h6 or h7 can be used
- Coolant through on all holders
- Bore for data carrier

Accessories:

Use preset Torque Wrench, 6 Nm, to ensure correct mounting of tools. Part no. 19050

ETP HYDRO-GRIP PENCIL can be used with reducing sleeves.

For additional information see section Accessories.



ETP HYDRO-GRIP® PENCIL BT Form AD - JIS B 6339

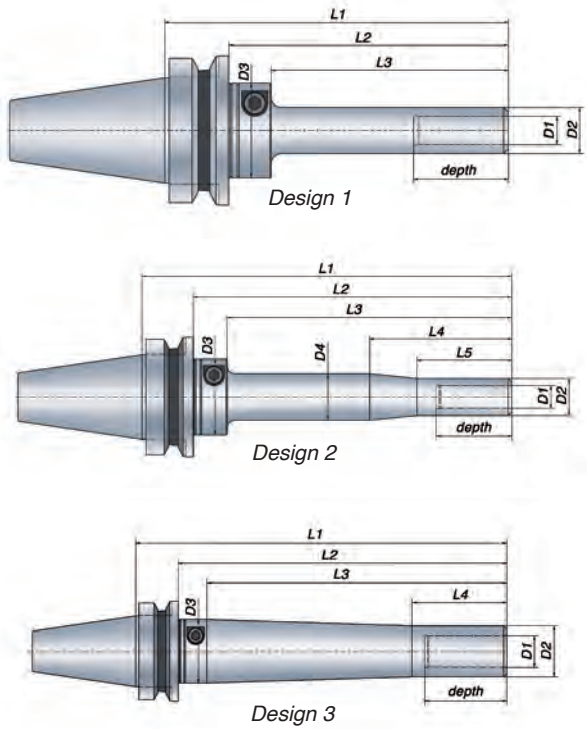

Metric range

Technical Specification BT form AD				Dimensions, mm												
Design	Taper	Part no.	Item description	D1	D2	D3	D4	L1	L2	L3	L4	L5	depth	T* Nm	Weight kg	G 2.5 at rpm
● 1	30	683000	HG PENCIL-6x50/BT30	6	12	40		90	68	50			40	12-22	0.6	25 000
○ 1		683010	HG PENCIL-8x50/BT30	8	14.5	40		90	68	50			40	27-40	0.6	25 000
○ 1		683030	HG PENCIL-10x50/BT30	10	17	40		90	68	50			40	35-70	0.6	25 000
○ 1		683020	HG PENCIL-10x100/BT30	10	17	40		140	118	100			40	35-70	0.7	15 000
● 1		683060	HG PENCIL-12x50/BT30	12	19.5	40		90	68	50			40	60-125	0.6	25 000
● 1		683040	HG PENCIL-12x100/BT30	12	19.5	40		140	118	100			40	60-125	0.7	15 000
● 2		683050	HG PENCIL-12x150/BT30	12	19.5	40	24.5	190	168	150	75	50	40	60-125	1	10 000
○ 3		684360	HG PENCIL-20x110/BT30	20	32	40		150	128	110	60		52	260-425	1.2	0 000
○ 3		684370	HG PENCIL-20x190/BT30	20	32	40		230	208	190	60		52	260-425	1.8	10 000

Inch range

Technical Specification BT form AD				Dimensions, inch												
Design	Taper	Part no.	Item description	D1	D2	D3	D4	L1	L2	L3	L4	L5	depth	T* ft-lb	Weight kg	G 2.5 at rpm
○ 1	30	683000-T	HG PENCIL-1/4"x50/BT30	0.250	0.472	1.575		3.543	2.677	1.969			1.575	13-20	0.6	25 000
● 1		683060-T	HG PENCIL-1/2"x50/BT30	0.500	0.768	1.575		3.543	2.677	1.969			1.575	55-105	0.6	25 000
● 1		683040-T	HG PENCIL-1/2"x100/BT30	0.500	0.768	1.575		5.512	4.646	3.937			1.575	55-105	0.7	15 000
○ 2		683050-T	HG PENCIL-1/2"x150/BT30	0.500	0.768	1.575	0.965	7.480	6.614	5.906	2.953	1.969	1.575	55-105	1	10 000

*) T = Min. and Max. transmittable torque using a h6 cylindrical tool, full depth insert. For additional information see section Technical Information.

- From stock
- On request

Information:

- Runout accuracy ≤ 0.004 mm at $2.5 \times D1$ (max. 50 mm), ≤ 0.00016 inch at $2.5 \times D1$ (max. 1.969 inch)
- ≤ 0.007 mm at $2.5 \times D1$ at length $L1 > 125$ mm
- ≤ 0.00028 inch at $2.5 \times D1$ at length $L1 > 4.921$ inch
- Tool shank h6 or h7 can be used
- Coolant through on all holders
- Bore for data carrier - available on request

Accessories:

Use preset Torque Wrench, 6 Nm, to ensure correct mounting of tools. Part no. 19050.

ETP HYDRO-GRIP PENCIL can be used with reducing sleeves. For additional information see section Accessories.



ETP HYDRO-GRIP® PENCIL

BT Form AD - JIS B 6339 Dual Contact

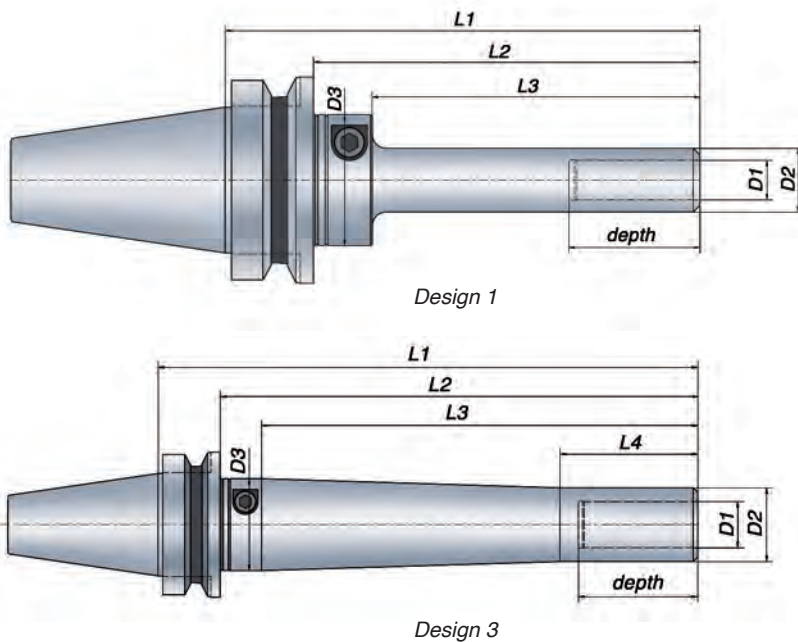

Metric range

Technical Specification <i>BT form AD</i>				Dimensions, mm												
Design	Taper	Part no.	Item description	D1	D2	D3	D4	L1	L2	L3	L4	L5	depth	T* Nm	Weight kg	G 2.5 at rpm
● 1	30	684700	HG PENCIL-12x50/DC-BT30	12	19.5	40		102	80	50			40	60 - 125	0.6	25 000
● 1		684710	HG PENCIL-12x100/DC-BT30	12	19.5	40		152	130	100			40	60 - 125	0.7	15 000
○ 3		684930	HG PENCIL-20x110/DC-BT30	20	32	40		162	140	110	60		52	260 - 425	1.2	20 000

Inch range

Technical Specification <i>BT form AD</i>				Dimensions, inch												
Design	Taper	Part no.	Item description	D1	D2	D3	D4	L1	L2	L3	L4	L5	depth	T* ft-lb	Weight kg	G 2.5 at rpm
● 1	30	684700-T	HG PENCIL-1/2"x50/DC-BT30	0.500	0.767	1.575		4.016	3.150	1.969			1.575	55 - 105	0.6	25 000
● 1		684710-T	HG PENCIL-1/2"x100/DC-BT30	0.500	0.767	1.575		5.984	5.118	3.937			1.575	55 - 105	0.7	15 000
○ 3		684930-T	HG PENCIL-20x110/DC-BT30	0.750	1.260	1.575		6.378	5.512	4.330	2.362		2.047	192 - 314	1.2	20 000

*) T = Min. and Max. transmittable torque using a h6 cylindrical tool, full depth insert. For additional information see section Technical Information.

- From stock
- On request

Information:

- Runout accuracy ≤ 0.004 mm at $2.5 \times D1$ (max. 50 mm), ≤ 0.00016 inch at $2.5 \times D1$ (max. 1.969 inch)
- ≤ 0.007 mm at $2.5 \times D1$ at length $L1 > 125$ mm
- ≤ 0.00028 inch at $2.5 \times D1$ at length $L1 > 4.921$ inch
- Tool shank h6 or h7 can be used
- Coolant through on all holders
- Bore for data carrier - available on request

Accessories:

Use preset Torque Wrench, 6 Nm, to ensure correct mounting of tools. Part no. 19050.

ETP HYDRO-GRIP PENCIL can be used with reducing sleeves.
For additional information see section Accessories.



ETP HYDRO-GRIP® PENCIL

BT Form AD/B - JIS B 6339

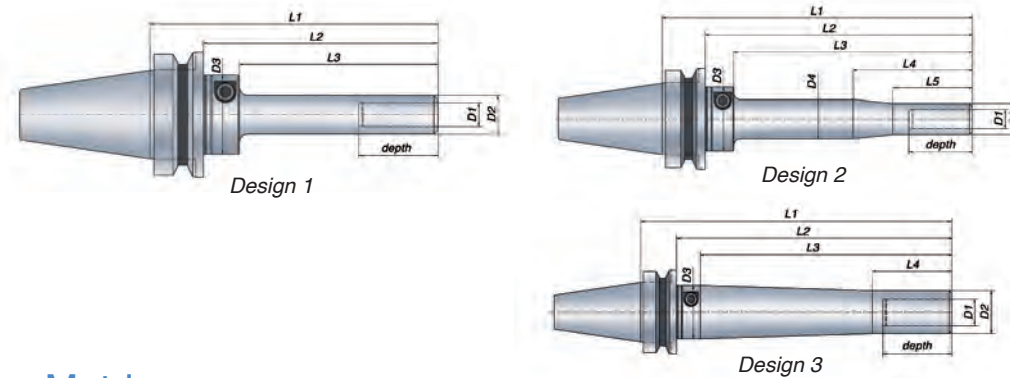

Slim
and long
reach



Metric range

Technical Specification BT form AD/B

Design	Taper	Part no.	Item description	Dimensions, mm											T* Nm	Weight kg	G 2.5 at rpm	
				D1	D2	D3	D4	L1	L2	L3	L4	L5	depth					
● 1	40	683070	HG PENCIL-6x50/BT40	6	12	40		95	68	50					40	12-22	1.2	25 000
○ 1		683080	HG PENCIL-8x50/BT40	8	14.5	40		95	68	50				40	27-40	1.2	25 000	
○ 1		683100	HG PENCIL-10x50/BT40	10	17	40		95	68	50				40	35-70	1.2	25 000	
○ 1		683090	HG PENCIL-10x100/BT40	10	17	40		145	118	100				40	35-70	1.3	15 000	
● 1		683160	HG PENCIL-12x50/BT40	12	19.5	40		95	68	50				40	60-125	1.2	25 000	
● 1		683170	HG PENCIL-12x100/BT40	12	19.5	40		145	118	100				40	60-125	1.3	15 000	
● 2		683110	HG PENCIL-12x150/BT40	12	19.5	40	24.5	195	168	150	75	50		40	60-125	1.6	0 000	
○ 1		683130	HG PENCIL-16x75/BT40	16	26	40		120	93	75				50	165-270	1.4	15 000	
○ 1		683120	HG PENCIL-16x125/BT40	16	26	40		170	143	125				50	165-270	1.6	10 000	
● 3		683150	HG PENCIL-20x110/BT40	20	32	40		155	128	110	60			52	260-425	1.8	20 000	
● 3		683140	HG PENCIL-20x190/BT40	20	32	40		235	208	190	60			52	260-425	2.4	10 000	
● 1	50	684090	HG PENCIL 12x50/BT50	12	19.5	40		106	68	50				40	60-110	3.8	14 000	
● 1		684100	HG PENCIL 12x100/BT50	12	19.5	40		156	118	100				40	60-110	3.9	14 000	
● 2		684110	HG PENCIL 12x150/BT50	12	19.5	40	24.5	206	168	150	75	50		40	60-110	4.2	10 000	
● 3		684140	HG PENCIL 20x110/BT50	20	32	40		166	128	110	60			52	260-425	4.4	14 000	
● 3		684150	HG PENCIL 20x190/BT50	20	32	40		246	206.5	190	60			52	260-425	5	10 000	

Inch range

Technical Specification BT form AD/B

Design	Taper	Part no.	Item description	Dimensions, inch											T* ft-lb	Weight kg	G 2.5 at rpm	
				D1	D2	D3	D4	L1	L2	L3	L4	L5	depth					
○ 1	40	683070-T	HG PENCIL-1/4"x50/BT40	0.250	0.472	1.575		3.740	2.677	1.969					1.575	13-20	1.2	25 000
○ 1		683160-T	HG PENCIL-1/2"x50/BT40	0.500	0.768	1.575		3.740	2.677	1.969				1.575	55-105	1.2	25 000	
○ 1		683170-T	HG PENCIL-1/2"x100/BT40	0.500	0.768	1.575		5.709	4.646	3.937				1.575	55-105	1.3	15 000	
○ 2		683110-T	HG PENCIL-1/2"x150/BT40	0.500	0.768	1.575	0.965	7.677	6.614	5.906	2.953	1.969		1.575	55-105	1.6	10 000	
○ 3		683150-T	HG PENCIL-3/4"x110/BT40	0.750	1.260	1.575		6.102	5.039	4.331	2.362			2.047	192-314	1.8	20 000	
○ 3		683140-T	HG PENCIL-3/4"x190/BT40	0.750	1.260	1.575		9.252	8.189	7.480	2.362			2.047	192-314	2.4	10 000	
○ 1	50	684090-T	HG PENCIL 1/2"x50/BT50	0.500	0.768	1.575		4.173	2.677	1.969				1.575	55-105	3.8	14 000	
○ 1		684100-T	HG PENCIL 1/2"x100/BT50	0.500	0.768	1.575		6.142	4.646	3.937				1.575	55-105	3.9	14 000	
○ 2		684110-T	HG PENCIL 1/2"x150/BT50	0.500	0.768	1.575	0.965	8.110	6.614	5.906	2.953	1.969		1.575	55-105	4.2	10 000	
○ 3		684140-T	HG PENCIL 3/4"x110/BT50	0.750	1.260	1.575		6.535	5.039	4.331	2.362			2.047	192-314	4.4	14 000	
○ 3		684150-T	HG PENCIL 3/4"x190/BT50	0.750	1.260	1.575		9.685	8.130	7.480	2.362			2.047	192-314	5	10 000	

*) T = Min. and Max. transmittable torque using a h6 cylindrical tool, full depth insert. For additional information see section Technical Information.

- From stock
- On request

Information:

- Runout accuracy ≤ 0.004 mm at $2.5 \times D1$ (max. 50 mm), ≤ 0.00016 inch at $2.5 \times D1$ (max. 1.969 inch)
- ≤ 0.007 mm at $2.5 \times D1$ at length $L1 > 125$ mm
- ≤ 0.00028 inch at $2.5 \times D1$ at length $L1 > 4.921$ inch
- Tool shank h6 or h7 can be used
- Coolant through on all holders
- Bore for data carrier - available on request

Accessories:

Use preset Torque Wrench, 6 Nm, to ensure correct mounting of tools. Part no. 19050.

ETP HYDRO-GRIP PENCIL can be used with reducing sleeves.

For additional information see section Accessories.



ETP HYDRO-GRIP® PENCIL

CAT Form AD/B - ASME B5.50

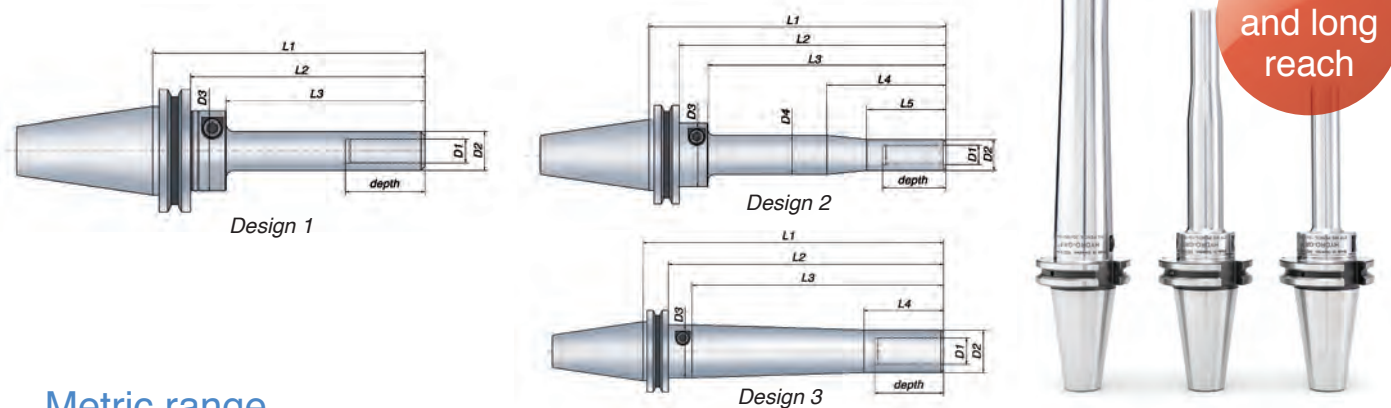

Metric range

Technical Specification CAT form AD/B

Design	Taper	Part no.	Item description	Dimensions, mm											depth	T* Nm	Weight kg	G 2.5 at rpm
				D1	D2	D3	D4	L1	L2	L3	L4	L5						
● 1	40	683560	HG PENCIL-6x50/CAT40	6	12	40		88	68.95	50				40	12-22	1	25 000	
○ 1		683570	HG PENCIL-8x50/CAT40	8	14.5	40		88	68.95	50				40	27-40	1	25 000	
○ 1		683590	HG PENCIL-10x50/CAT40	10	17	40		88	68.95	50				40	35-70	1	25 000	
○ 1		683580	HG PENCIL-10x100/CAT40	10	17	40		138	118.95	100				40	35-70	1.1	15 000	
● 1		683650	HG PENCIL-12x50/CAT40	12	19.5	40		88	68.95	50				40	60-125	1	25 000	
● 1		683600	HG PENCIL-12x100/CAT40	12	19.5	40		138	118.95	100				40	60-125	1.1	15 000	
● 2		683610	HG PENCIL-12x150/CAT40	12	19.5	40	24.5	188	168.95	150	75	50	40	60-125	1.4	10 000		
○ 1		683630	HG PENCIL-16x75/CAT40	16	26	40		113	93.95	75				50	165-270	1.2	15 000	
○ 1		683620	HG PENCIL-16x125/CAT40	16	26	40		163	143.95	125				50	165-270	1.4	10 000	
● 3		683660	HG PENCIL-20x110/CAT40	20	32	40		148	128.95	110	60			52	260-425	1.6	20 000	
● 3		683640	HG PENCIL-20x190/CAT40	20	32	40		228	208.95	190	60			52	260-425	2.3	10 000	
● 1	50	684290	HG PENCIL 12x50/CAT50	12	19.5	40		88	68.95	50				40	60-125	2.9	14 000	
● 1		684300	HG PENCIL 12x100/CAT50	12	19.5	40		138	118.95	100				40	60-125	3	14 000	
● 2		684310	HG PENCIL 12x150/CAT50	12	19.5	40	24.5	188	168.95	150	75	50	40	60-125	3.2	10 000		
● 3		684340	HG PENCIL 20x110/CAT50	20	32	40		148	128.95	110	60			52	260-425	3.4	14 000	
● 3		684350	HG PENCIL 20x190/CAT50	20	32	40		228	208.95	190	60			52	260-425	4.1	10 000	

Inch range

Technical Specification CAT form AD/B

Design	Taper	Part no.	Item description	Dimensions, inch											depth	T* ft-lb	Weight kg	G 2.5 at rpm
				D1	D2	D3	D4	L1	L2	L3	L4	L5						
● 1	40	683560-T	HG PENCIL-1/4"x50/CAT40	0.250	0.472	1.575		3.465	2.715	1.969				1.575	13-20	1	25 000	
● 1		683650-T	HG PENCIL-1/2"x50/CAT40	0.500	0.768	1.575		3.465	2.715	1.969				1.575	55-105	1	25 000	
● 1		683600-T	HG PENCIL-1/2"x100/CAT40	0.500	0.768	1.575		5.433	4.683	3.937				1.575	55-105	1.1	15 000	
● 2		683610-T	HG PENCIL-1/2"x150/CAT40	0.500	0.768	1.575	0.965	7.402	6.652	5.906	2.953	1.969	1.575	55-105	1.4	10 000		
● 3		683660-T	HG PENCIL-3/4"x110/CAT40	0.750	1.260	1.575		5.827	5.077	4.331	2.362			2.047	192-314	1.6	20 000	
● 3		683640-T	HG PENCIL-3/4"x190/CAT40	0.750	1.260	1.575		8.976	8.226	7.480	2.362			2.047	192-314	2.3	10 000	
● 1	50	684290-T	HG PENCIL 1/2"x50/CAT50	0.500	0.768	1.575		3.465	2.715	1.969				1.575	55-105	2.9	14 000	
● 1		684300-T	HG PENCIL 1/2"x100/CAT50	0.500	0.768	1.575		5.433	4.683	3.937				1.575	55-105	3	14 000	
● 2		684310-T	HG PENCIL 1/2"x150/CAT50	0.500	0.768	1.575	0.965	7.402	6.652	5.906	2.953	1.969	1.575	55-105	3.2	10 000		
● 3		684340-T	HG PENCIL 3/4"x110/CAT50	0.750	1.260	1.575		5.827	5.077	4.331	2.362			2.047	192-314	3.4	14 000	
● 3		684350-T	HG PENCIL 3/4"x190/CAT50	0.750	1.260	1.575		8.976	8.226	7.480	2.362			2.047	192-314	4.1	10 000	

*) T = Min. and Max. transmittable torque using a h6 cylindrical tool, full depth insert. For additional information see section Technical Information.

- From stock
- On request

Information:

- Runout accuracy ≤ 0.004 mm at $2.5 \times D1$ (max. 50 mm), ≤ 0.00016 inch at $2.5 \times D1$ (max. 1.969 inch)
- ≤ 0.007 mm at $2.5 \times D1$ at length $L1 > 125$ mm
- ≤ 0.00028 inch at $2.5 \times D1$ at length $L1 > 4.921$ inch
- Tool shank h6 or h7 can be used
- Coolant through on all holders
- Bore for data carrier

Accessories:

Use preset Torque Wrench, 6 Nm, to ensure correct mounting of tools. Part no. 19050.

ETP HYDRO-GRIP PENCIL can be used with reducing sleeves.

For additional information see section Accessories.



ETP HYDRO-GRIP® PENCIL

CAT Form AD/B - ASME B5.50 Dual Contact

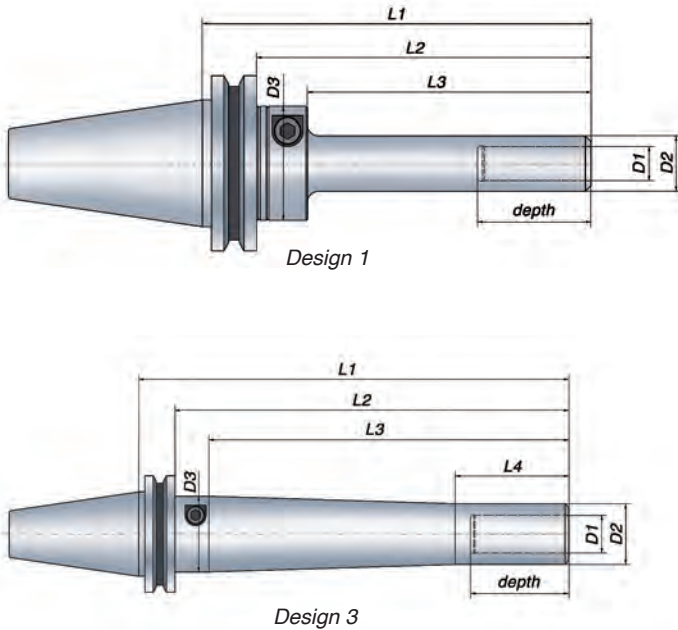

Metric range

Technical Specification CAT form AD/B Dual Contact

Design	Taper	Part no.	Item description	Dimensions, mm											depth	T* Nm	Weight kg	G 2.5 at rpm	
				D1	D2	D3	D4	L1	L2	L3	L4	L5							
1	40	684830	HG PENCIL-12x50/DC-CAT40	12	19.5	40		100	80.95	50						40	60-125	1.2	25 000
1		684840	HG PENCIL-12x100/DC-CAT40	12	19.5	40		150	130.95	100						40	60-125	1.3	15 000
3		684860	HG PENCIL-20x110/DC-CAT40	20	32	40		160	140.95	110	60					52	260-425	1.8	20 000

Inch range

Technical Specification CAT form AD/B Dual Contact

Design	Taper	Part no.	Item description	Dimensions, inch											depth	T* ft-lb	Weight kg	G 2.5 at rpm	
				D1	D2	D3	D4	L1	L2	L3	L4	L5							
1	40	684830-T	HG PENCIL-1/2"x50/DC-CAT40	0.500	0.768	1.575		3.937	3.187	1.969						1.575	55-105	1.2	25 000
1		684840-T	HG PENCIL-1/2"x100/DC-CAT40	0.500	0.768	1.575		5.906	5.156	3.937						1.575	55-105	1.3	15 000
3		684860-T	HG PENCIL-3/4"x110/DC-CAT40	0.750	1.220	1.575		6.299	5.549	4.331	2.362					2.047	192-314	1.8	20 000

*) T = Min. and Max. transmittable torque using a h6 cylindrical tool, full depth insert. For additional information see section Technical Information.

- From stock
- On request

Information:

- Runout accuracy ≤ 0.004 mm at $2.5 \times D1$ (max. 50 mm), ≤ 0.00016 inch at $2.5 \times D1$ (max. 1.969 inch)
- ≤ 0.007 mm at $2.5 \times D1$ at length $L1 > 125$ mm
- ≤ 0.00028 inch at $2.5 \times D1$ at length $L1 > 4.921$ inch
- Tool shank h6 or h7 can be used
- Coolant through on all holders
- Bore for data carrier

Accessories:

Use preset Torque Wrench, 6 Nm, to ensure correct mounting of tools. Part no. 19050.

ETP HYDRO-GRIP can be used with reducing sleeves. For additional information see section Accessories.



ETP HYDRO-GRIP® PENCIL PSK Form - ISO 26623-1

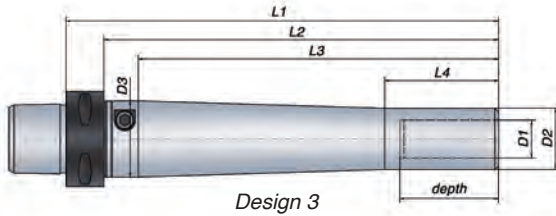
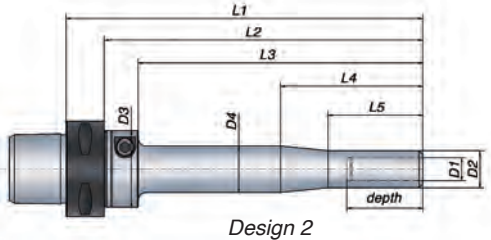
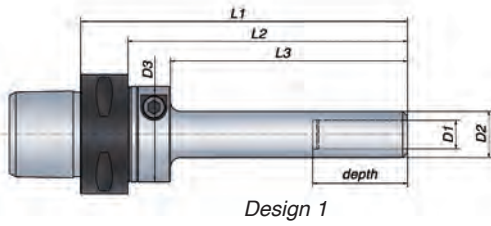

Metric range

Technical Specification PSK form

Dimensions, mm

Design	Coupling size	Part no.	Item description	D1	D2	D3	D4	L1	L2	L3	L4	L5	depth	T* Nm	Weight kg	G 2.5 at rpm	
●	1	C4	683210	HG PENCIL-6x50/C4	6	12	40		88		50		40	12-22	0.5	25 000	
○	1		683180	HG PENCIL-8x50/C4	8	14.5	40		88		50		40	27-40	0.5	25 000	
○	1		683200	HG PENCIL-10x50/C4	10	17	40		88		50		40	35-70	0.5	25 000	
○	1		683190	HG PENCIL-10x100/C4	10	17	40		138		100		40	35-70	0.6	15 000	
●	1		683220	HG PENCIL-12x50/C4	12	19.5	40		88		50		40	60-125	0.5	25 000	
●	1		683230	HG PENCIL-12x100/C4	12	19.5	40		138		100		40	60-125	0.6	15 000	
●	2		683240	HG PENCIL-12x150/C4	12	19.5	40	24.5	188		150	75	50	40	60-125	0.8	10 000
●	1	C5	683310	HG PENCIL-6x50/C5	6	12	40		88	68	50		40	12-22	0.6	25 000	
○	1		683250	HG PENCIL-8x50/C5	8	14.5	40		88	68	50		40	27-40	0.6	25 000	
○	1		683270	HG PENCIL-10x50/C5	10	17	40		88	68	50		40	35-70	0.6	25 000	
○	1		683260	HG PENCIL-10x100/C5	10	19.5	40		138	118	100		40	35-70	0.7	15 000	
●	1		683320	HG PENCIL-12x50/C5	12	19.5	40		88	68	50		40	60-125	0.6	25 000	
●	1		683330	HG PENCIL-12x100/C5	12	19.5	40		138	118	100		40	60-125	0.7	15 000	
●	2		683300	HG PENCIL-12x150/C5	12	19.5	40	24.5	188	168	150	75	50	40	60-125	0.9	10 000
○	1		683290	HG PENCIL-16x75/C5	16	26	40		113	93	75		50	165 - 270	0.8	15 000	
○	1		683280	HG PENCIL-16x125/C5	16	26	40		163	143	125		50	165 - 270	1	10 000	
●	3		683340	HG PENCIL-20x110/C5	20	32	40		148	128	110	60	52	260 - 425	1.2	20 000	
●	3		683350	HG PENCIL-20x190/C5	20	32	40		228	208	190	60	52	260 - 425	1.9	10 000	

*) T = Min. and Max transmittable torque using a h6 cylindrical tool, full depth insert. For additional information see section Technical Information.

PSK Inch equivalents add "-T" to metric part no. Available on request.

● From stock

○ On request

Information:

- Runout accuracy ≤ 0.004 mm at $2.5 \times D1$ (max. 50 mm),
 ≤ 0.00016 inch at $2.5 \times D1$ (max. 1.969 inch)
 ≤ 0.007 mm at $2.5 \times D1$ at length $L1 > 125$ mm
 ≤ 0.00028 inch at $2.5 \times D1$ at length $L1 > 4.921$ inch
- Tool shank h6 or h7 can be used
- Coolant through on all holders
- Bore for data carrier - available on request

Accessories:

Use preset Torque Wrench, 6 Nm, to ensure correct mounting of tools. Part no. 19050.

ETP HYDRO-GRIP PENCIL can be used with reducing sleeves.
For additional information see section Accessories.



ETP HYDRO-GRIP® PENCIL PSK Form - ISO 26623-1

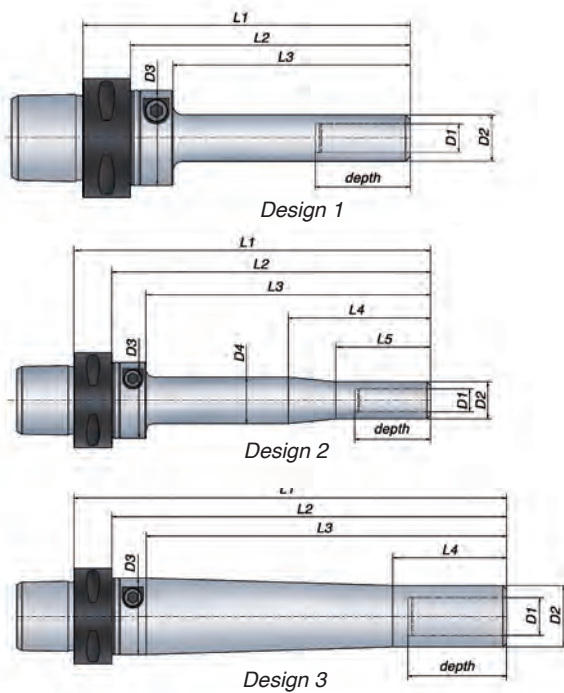

Metric range

Technical Specification PSK form				Dimensions, mm													
Design	Coupling size	Part no.	Item description	D1	D2	D3	D4	L1	L2	L3	L4	L5	depth	T* Nm	Weight kg	G 2.5 at rpm	
●	1	C6	683430	HG PENCIL-6x50/C6	6	12	40		90	68	50		40	12-22	1	25 000	
○	1		683360	HG PENCIL-8x50/C6	8	14.5	40		90	68	50		40	27-40	1	25 000	
○	1		683380	HG PENCIL-10x50/C6	10	17	40		90	68	50		40	35-70	1	25 000	
●	1		683370	HG PENCIL-10x100/C6	10	17	40		140	118	100		40	35-70	1.1	15 000	
●	1		683440	HG PENCIL-12x50/C6	12	19.5	40		90	68	50		40	60-125	1	25 000	
●	1		683450	HG PENCIL-12x100/C6	12	19.5	40		140	118	100		40	60-125	1.1	15 000	
●	2		683410	HG PENCIL-12x150/C6	12	19.5	40	24.5	190	168	150	75	50	40	60-125	1.3	10 000
○	1		683400	HG PENCIL-16x75/C6	16	26	40		115	93	75		50	165 - 270	1.2	15 000	
○	1		683390	HG PENCIL-16x125/C6	16	26	40		165	143	125		50	165 - 270	1.4	10 000	
●	3		683460	HG PENCIL-20x110/C6	20	32	40		150	128	110	60	52	260 - 425	1.6	20 000	
●	3		683420	HG PENCIL-20x190/C6	20	32	40		230	208	190	60	52	260 - 425	2.2	10 000	
○	1	C8	683480	HG PENCIL-10x50/C8	10	17	40		102	72	50		40	35-70	2.1	14 000	
○	1		683470	HG PENCIL-10x100/C8	10	17	40		152	122	100		40	35-70	2.2	14 000	
●	1		683510	HG PENCIL-12x50/C8	12	19.5	40		102	72	50		40	60-125	2.1	14 000	
●	1		683520	HG PENCIL-12x100/C8	12	19.5	40		152	122	100		40	60-125	2.2	14 000	
●	2		683540	HG PENCIL-12x150/C8	12	19.5	40	24.5	202	172	150	75	50	40	60-125	2.4	10 000
○	1		683500	HG PENCIL-16x75/C8	16	26	40		127	97	75		50	165 - 270	2.3	14 000	
○	1		683490	HG PENCIL-16x125/C8	16	26	40		177	147	125		50	165 - 270	2.5	10 000	
●	3		683530	HG PENCIL-20x110/C8	20	32	40		162	132	110	60	52	260 - 425	2.6	14 000	
●	3		683550	HG PENCIL-20x190/C8	20	32	40		242	212	190	60	52	260 - 425	3.3	10 000	

*) T = Min. and Max transmittable torque using a h6 cylindrical tool, full depth insert. For additional information see section Technical Information.

PSK Inch equivalents add "-T" to metric part no. Available on request.

- From stock
- On request

Information:

- Runout accuracy ≤ 0.004 mm at $2.5 \times D1$ (max. 50 mm), ≤ 0.00016 inch at $2.5 \times D1$ (max. 1.969 inch)
- ≤ 0.007 mm at $2.5 \times D1$ at length $L1 > 125$ mm
- ≤ 0.00028 inch at $2.5 \times D1$ at length $L1 > 4.921$ inch
- Tool shank h6 or h7 can be used
- Coolant through on all holders
- Bore for data carrier - available on request

Accessories:

Use preset Torque Wrench, 6 Nm, to ensure correct mounting of tools. Part no. 19050.

ETP HYDRO-GRIP PENCIL can be used with reducing sleeves. For additional information see section Accessories.



ETP HYDRO-GRIP® PENCIL

Cylindrical extension

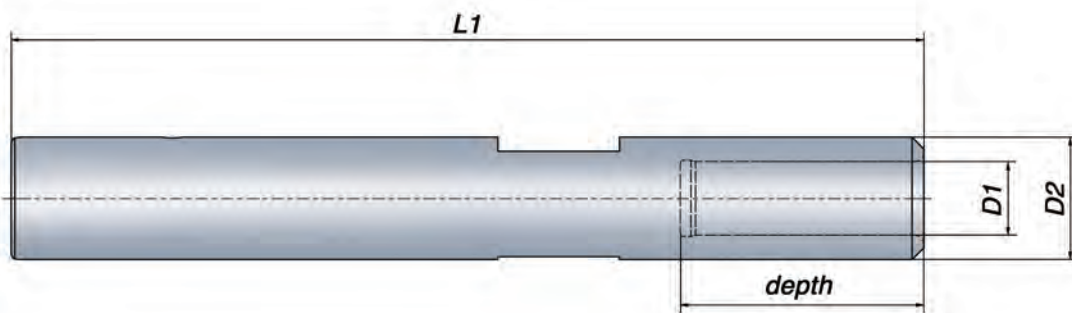
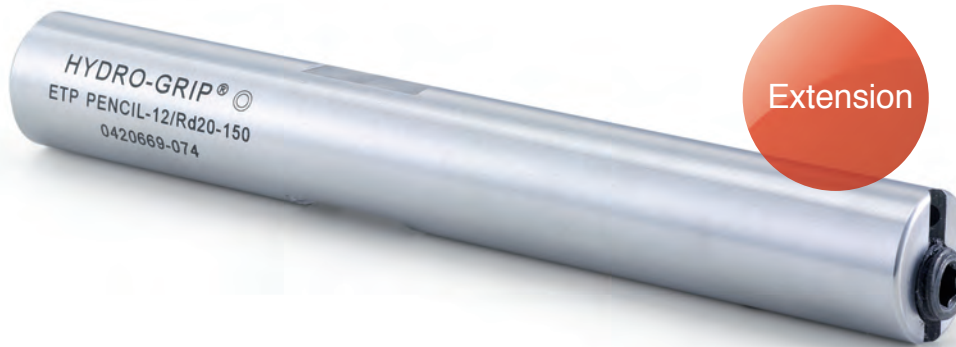

Metric range

Technical Specification

Part no.	Item description	Dimensions, mm						
		D1	D2	L1	depth	T* Nm	Weight kg	G 2.5 at rpm
336891	HG PENCIL-12/Rd20-150	12	20	150	40	60 - 125	0.3	15 000

*) T = Min. and Max transmittable torque using a h6 cylindrical tool, full depth insert. For additional information see section Technical Information.

- From stock
- On request

Information:

- Runout accuracy ≤ 0.004 mm at $2.5 \times D1$ (max. 50 mm),
 ≤ 0.00016 inch at $2.5 \times D1$ (max. 1.969 inch)
- Tool shank h6 or h7 can be used
- Coolant through

Accessories:

Use preset Torque Wrench, 6 Nm, to ensure correct mounting of tools. Part no. 19050.

ETP HYDRO-GRIP PENCIL can be used with reducing sleeves.
For additional information see section Accessories.

