



Benefits and features

- Several tools can be mounted on the same sleeve
- Reduces set up time
- Pressurizing is carried out with a high pressure pump
- Allows design with longer sleeves

ETP HYDRO-GRIP® C

Sleeve for interchangeable tool assembly which can easily be switched between different tools. The tool is fastened to the sleeve by bolts through the collar. Several tools can be mounted simultaneously on the same sleeve. Pressurizing is carried out with a high pressure grease pump. This allows the use of longer sleeves.

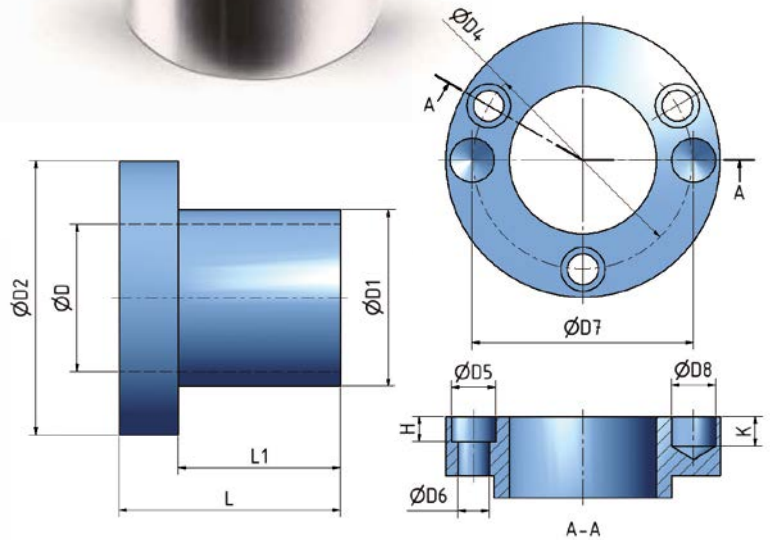

Technical specification ETP HYDRO-GRIP® C

Type	D	D1	D2	D4	D5	D6	D7	D8	H	K	L	L1
C-40/60-75	40	60	93	74	14	9.5	75	15	8.5	10	75	55
C-40/60-95	40	60	93	74	14	9.5	75	15	8.5	10	95	75
C-40/60-115	40	60	93	74	14	9.5	75	15	8.5	10	115	95
C-40/60-165	40	60	93	74	14	9.5	75	15	8.5	10	165	145
C-45/60-75*	45	60	93	74	14	9.5	70	M8	8.5		75	55
C-50/60-55*	50	60	93	74	14	9.5	75	15	8.5	10	55	35
C-50/60-75*	50	60	93	74	14	9.5	75	15	8.5	10	75	55
C-50/60-95*	50	60	93	74	14	9.5	75	15	8.5	10	95	75
C-50/60-115*	50	60	93	74	14	9.5	75	15	8.5	10	115	95
C-50/60-140*	50	60	93	74	14	9.5	75	15	8.5	10	140	120
C-50/60-190*	50	60	93	74	14	9.5	75	15	8.5	10	190	170
C-50/60-230*	50	60	93	74	14	9.5	75	15	8.5	10	230	210
C-60/70-75**	60	70	105	86	14	9.5	85	15	8.5	10	75	55
C-60/70-233	60	70	105	86	15	9.5	85	15	9	10	233	213
C-1 1/2"/50-85	1 1/2"	50	83	64	14	9.5	65	15	8.5	10	85	65
C-1 13/16"/60-75	1 13/16"	60	93	74	14	9.5	75	15	8.5	10	75	55
C-1 13/16"/65-85	1 13/16"	65	98	80	14	9.5	80	15	8.5	10	85	65
C-1 13/16"/65-135	1 13/16"	65	98	80	14	9.5	80	15	8.5	10	135	115

*) The sleeve has two, threaded M8-holes for carrier pegs, on a 70 mm pitch diameter.
 **) The sleeve has two, threaded M8-holes for carrier pegs, on a 85 mm pitch diameter.
 See section Technical Specification for more information.