

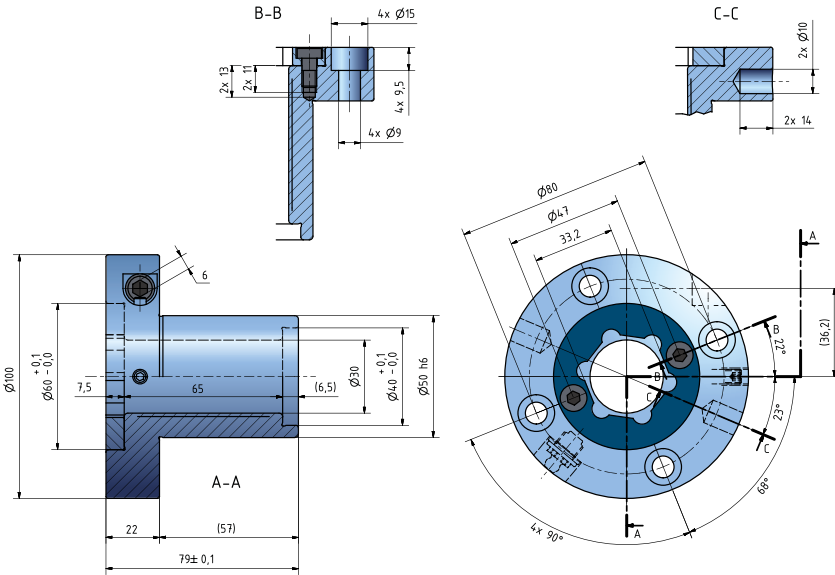

ETP HYDRO-GRIP® EI-30/50-79

Sleeve for **permanent tool assembly** and machines with hexagonal spindle profile. Safety disc is not included. (Part no. 99120)



ETP HYDRO-GRIP® EIS-30/50-79



ETP HYDRO-GRIP® EIS-30/50-79

Sleeve for **permanent tool assembly** and machines with hexagonal spindle profile. Safety disc is not included. (Part no. 99120)

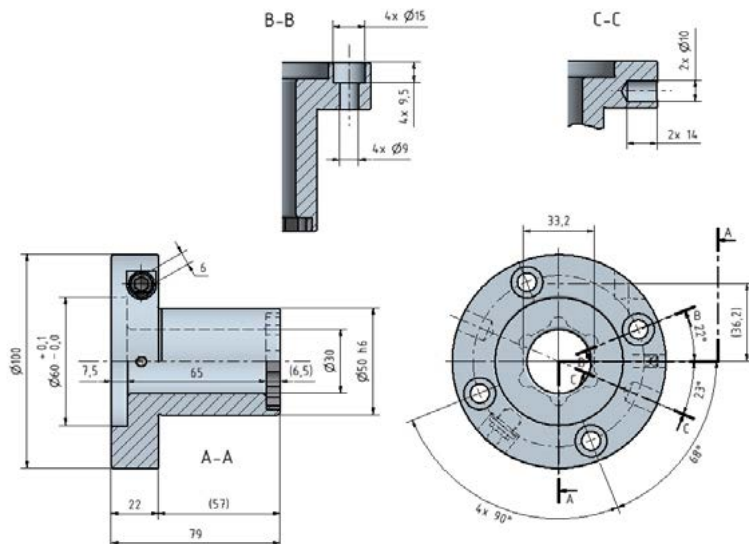



ETP HYDRO-GRIP® EI-40/80-92

Sleeve for **permanent tool assembly** and machines with hexagonal spindle profile. The sleeve is supplied with an internal hexagonal insert that can be used in either end of the sleeve. Safety disc is not included. (Part no. 99110)

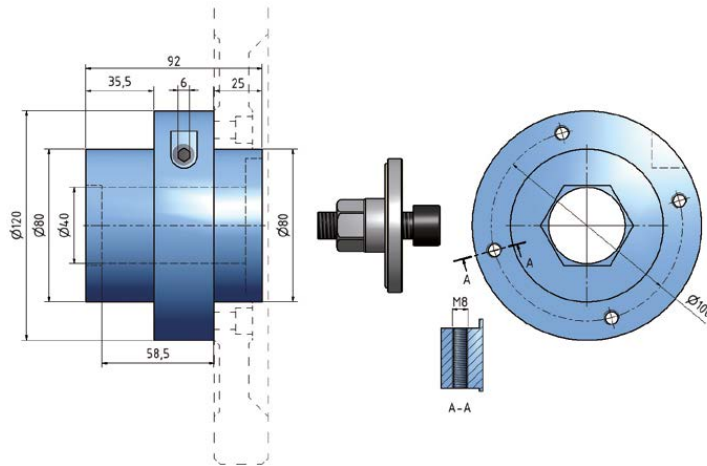

ETP HYDRO-GRIP® EIS-30/70-79



ETP HYDRO-GRIP® EIS-30/70-79

Sleeve for **permanent tool assembly** and machines with hexagonal spindle profile. Safety disc is not included. (Part no. 99120)

