

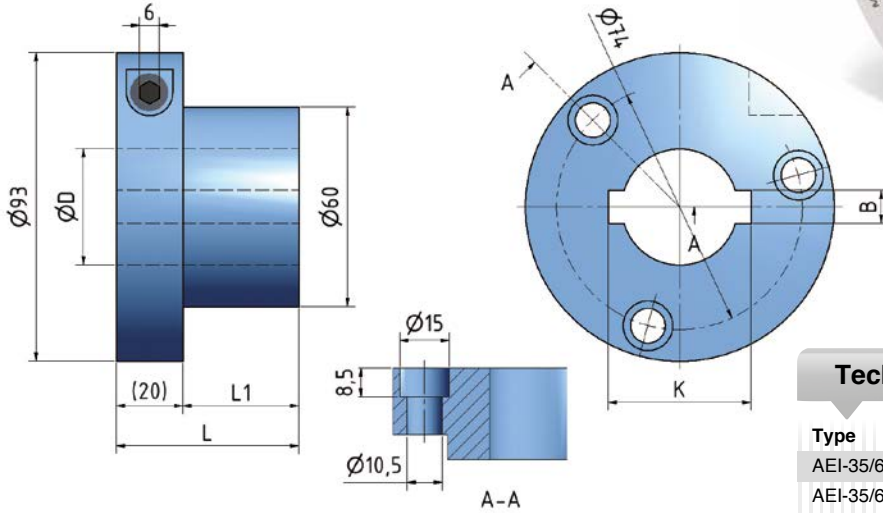

## ETP HYDRO-GRIP® AEI

Sleeve for permanent tool assembly and spindles with keys.



### Technical Specification

Type	D	L	L1	B	K	N
AEI-35/60-55	35	55	35	10	43	6
AEI-35/60-70	35	70	50	10	43	6
AEI-40/60-55	40	55	35	12	47	6

## ETP HYDRO-GRIP® EI



## ETP HYDRO-GRIP® EI

Sleeve for permanent tool assembly and spindles with keys.

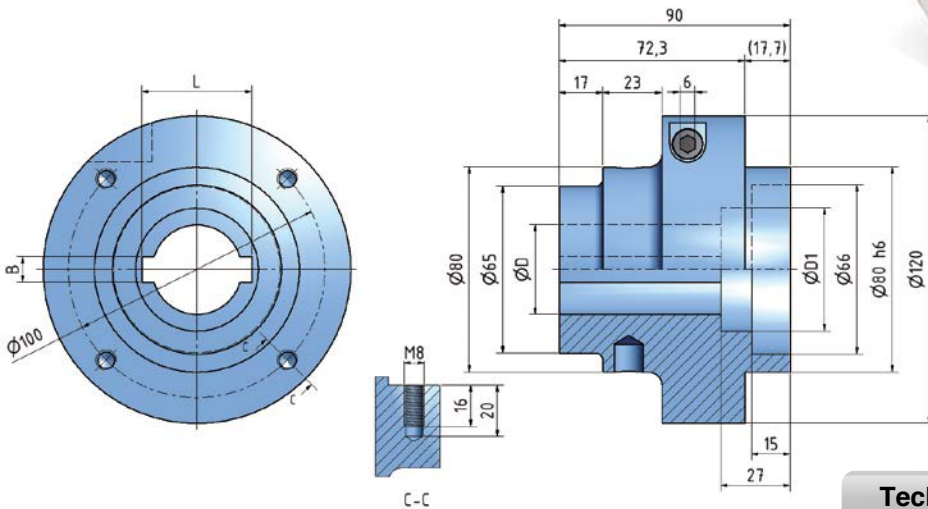

### Technical Specification

Type	D	D1	B	L
EI-35/80-90	35	48	10	43
EI-40/80-90	40	53	12	47



## ETP HYDRO-GRIP® AEI-100/130-50

Sleeve for **permanent tool assembly** and spindles with keys.  
Supplied with an aluminum tool ring.

