



Get a grip
– quick, easy and precise



**Innovation
for your
efficiency**

ETP Transmission AB has developed and manufactured hydraulic chucks and arbors for more than 40 years under the brand name ETP HYDRO-GRIP for the woodworking industry.

We are a global company and our customers are the leaders within their respective segments. This is the way we like it, working with people that demand the absolute best from us means we are constantly developing and improving ourselves and our products. It is your challenges that drive us forward.

This catalogue covers our standard products for the woodworking industry and in addition to this we also manufacture customized designed products for all types of wood machining.



**In need of
hydraulic
sleeves?**

**See our separate
Sleeve Catalogue!**



Quick, easy and precise

It takes just a few seconds to get perfect centering and fastening of your tools when attached to an ETP HYDRO-GRIP. The extremely high precision achieved by using ETP HYDRO-GRIP results in minimal runout, unrivalled repeatability and the best possible surface finish at super high feed speeds.

Our customers and worldwide users can confirm what this means in terms of dramatically improved cost-effectiveness.



Box 1120, SE-581 11
Linköping, Sweden
Tel. +46 (0)13 24 71 00
E-mail: info@etp.se
www.etp.se



Table of contents

Page

Hydraulic chucks

COMPACT HSK 63F		5
SLENDER HSK 63F		6
SLENDER SK30		7
COMBO HSK 63F		8
G3 HSK 63F		9
PENCIL HSK 63F		10

Hydraulic arbors

GEW2 PowerLock		12
GE2 HSK 63F		13
GE2 HSK 63F mod.		14

Accessories

Reduction sleeves		15-16
Extractor		16
Torque wrench		16



Hydraulic Chucks

Tough and compact design



Benefits and features

- Short overhang
- Easy handling
- High clamping force
- Can be used with reduction sleeves

ER
collet holder
replacement

ETP HYDRO-GRIP® COMPACT HSK 63F

The short design of 75 mm makes COMPACT your ideal replacement for any ER collet holder.

Allowing more and more users to fully benefit from all the positives of hydraulic clamping such as easy handling and decreased tool wear. COMPACT has a very compact and robust design. Tools changes are made quickly, easily and with a high level of precision. The high clamping force guarantees a secure clamping of your cutting tools. With a minimum tool runout a good surface finish is achieved along with an extended tool life.

COMPACT can be used with reduction sleeves for maximum flexibility.

short
design
75 mm

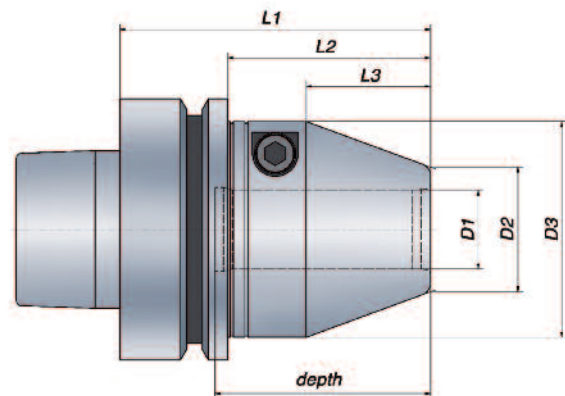

Technical Specification

HSK size	Part no.	Item description	Dimensions, mm									
			D1	D2	D3	L1	L2	L3	depth	T* Nm	Weight kg	G 2.5 at rpm
● 63	705762	HG COMPACT-12/HSK63F	12	22	43.5	75	49	18	40	60 - 125	1.1	25 000
● 63	705764	HG COMPACT-16/HSK63F	16	26	48	75	49	28	50	165 - 270	1.1	25 000
● 63	705766	HG COMPACT-20/HSK63F	20	30	52	75	49	30	52	260 - 425	1.1	25 000
● 63	706274	HG COMPACT-25/HSK63F	25	35	59	75	49	9	56	480 - 710	1.3	25 000

HSK size	Part no.	Item description	Dimensions, inch									
			D1	D2	D3	L1	L2	L3	depth	T* ft-lb	Weight kg	G 2.5 at rpm
● 63	705763	HG COMPACT-1/2"/HSK63F	0.500	0.866	1.713	2.953	1.929	0.709	1.575	55-105	1.1	25 000
● 63	705765	HG COMPACT-5/8"/HSK63F	0.625	1.024	1.890	2.953	1.929	1.102	1.969	122-199	1.1	25 000
● 63	705681	HG COMPACT-3/4"/HSK63F	0.750	1.181	2.047	2.953	1.929	1.181	2.047	192-314	1.1	25 000
● 63	706427	HG COMPACT-1"/HSK63F	1.000	1.378	2.323	2.953	1.929	0.354	2.205	354-524	1.3	25 000

^{*)} T_{min} = Minimum transmittable torque using a h6 cylindrical tool, full depth insert.

- Runout accuracy ≤ 0.004 mm at 2.5 x d1 (max. 50 mm)
≤ 0.00016 inch at 2.5x d1 (max. 1.969 inch)
- Tool shank h6 or h7 can be used



Benefits and features

- Quick and easy tool change
- High performance
- Slender design
- Excellent runout



ETP HYDRO-GRIP® SLENDER HSK 63F

HYDRO-GRIP SLENDER is extremely user friendly which means quick and easy tool changes. It has a tough and compact design and it is the most slender chuck in our range. A safety feature prevents the tool from falling out when the chuck is not pressurized. The tool shank must be equipped with a thread corresponding to the safety screw size.

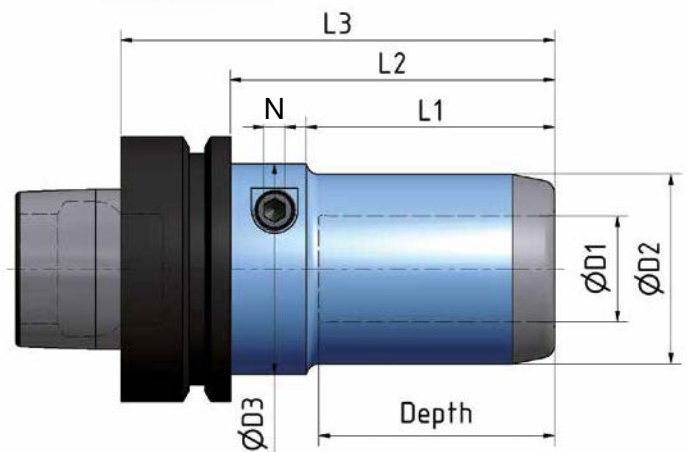

Technical specification ETP HYDRO-GRIP® SLENDER HSK 63F

Dimensions, mm

Part.no	Item description	D1	D2	D3	L1	L2	L3	Depth*	N	Max rpm
642680	SLENDER-12/HSK63F	12	32	40	43	61	87	40	5	25000
642690	SLENDER-16/HSK63F	16	38	40	43	61	87	40	5	25000
642700	SLENDER-20/HSK63F	20	40	50	55	73	99	52	5	25000
639130	SLENDER-25/HSK63F	25	45	50	59	77	103	56	5	25000
659400	SLENDER-3/8"/HSK63F	3/8"	32	40	43	61	87	40	5	25000
642710	SLENDER-1/2"/HSK63F	1/2"	32	40	43	61	87	40	5	25000
642720	SLENDER-5/8"/HSK63F	5/8"	38	40	43	61	87	40	5	25000
642730	SLENDER-3/4"/HSK63F	3/4"	40	50	55	73	99	52	5	25000
639140	SLENDER-1"/HSK63F	1"	45	50	59	77	103	56	5	25000

TOLERANCES

The type SLENDER chuck is designed and manufactured for a router bit shank with the tolerance g6 (h7). Transmittable torque for tools with tolerances:

Type	h6	h7	g6	Safety screw
D	Nm	Nm	Nm	ISO 4762
12	60	30	30	M6x40
16	100	75	75	M6x40
20	260	175	175	M8x45
25	480	350	350	M8x45
3/8"	30	15	15	M6x40
1/2"	60	30	30	M6x40
5/8"	100	75	75	M6x40
3/4"	260	175	175	M8x45
1"	480	350	350	M8x45

*)= clamping length

- The runout is measured at 3xD and the max runout is ≤ 0,006 mm (0.00024 inch).
- The type SLENDER chuck is balanced to G2,5 at 25000 rpm.
- A normally balanced chuck and tool can be used up to a max. speed of 25000 rpm.
- Can be used with reduction sleeves, see page 15-16 for assortment.

● From stock



**Tough
and compact
design**

Benefits and features

- Quick and easy tool change
- High performance
- Slender design
- Excellent runout

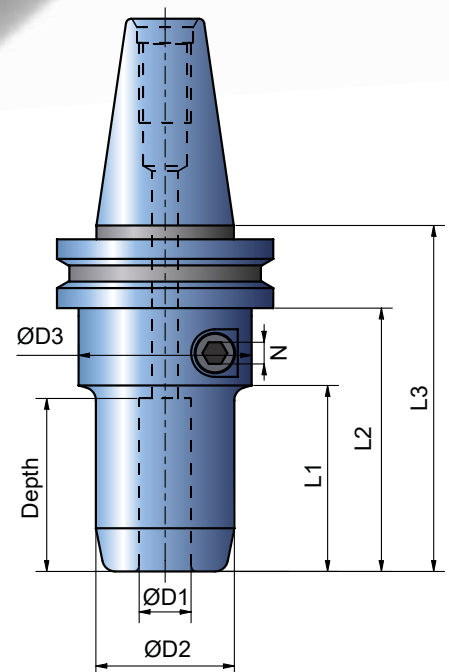

ETP HYDRO-GRIP® SLENDER SK30

HYDRO-GRIP type SLENDER is extremely user friendly which means quick and easy tool changes. It has a tough and compact design and it is the most slender chuck in our range. A safety feature prevents the tool from falling out when the chuck is not pressurized. The tool shank must be equipped with a thread corresponding to the safety screw size.

Technical specification ETP HYDRO-GRIP® SLENDER SK30

Dimensions, mm

Part.no	Item description	D1	D2	D3	L1	L2	L3	Depth*	N	Max rpm
701833	SLENDER-12/SK30	12	32	40	43	60,9	80	40	5	25000
702726	SLENDER-16/SK30	16	38	40	43	60,9	80	40	5	25000
702750	SLENDER-20/SK30	20	40	50	55	95,9	115	52	5	25000
701857	SLENDER-25/SK30	25	45	50	59	99,9	119	56	5	25000
702070	SLENDER-3/8"/SK30	3/8"	32	40	43	60,9	80	40	5	25000
702071	SLENDER-1/2"/SK30	1/2"	32	40	43	60,9	80	40	5	25000
702159	SLENDER-3/4"/SK30	3/4"	40	50	55	95,9	115	52	5	25000
703626	SLENDER-1"/SK30	1"	45	50	59	99,9	119	56	5	25000

*)= clamping length

- The runout is measured at 3xD and the max runout is $\leq 0,006$ mm (0.00024 inch).
- The type SLENDER chuck is balanced to G2,5 at 25000 rpm.
- A normally balanced chuck and tool can be used up to a max. speed of 25000 rpm.
- Can be used with reduction sleeves, see page 15-16 for assortment.

● From stock

TOLERANCES

The SLENDER chuck is designed and manufactured for a router bit shank with the tolerance g6 (h7). Transmittable torque for tools with tolerances:

Type	h6	h7	g6	Safety screw
D	Nm	Nm	Nm	ISO 4762
12	60	30	30	M6x40
16	100	75	75	M6x40
20	260	175	175	M8x45
25	480	350	350	M8x45
3/8"	30	15	15	M6x40
1/2"	60	30	30	M6x40
3/4"	260	175	175	M8x45
1"	480	350	350	M8x45



Benefits and features

- Quick, easy and independent tool change
- Multiple tool combination
- Optimized run time for each tool
- High performance and excellent run out

ETP HYDRO-GRIP® COMBO HSK 63F

The new COMBO let you enjoy all the benefits using a hydraulic chuck for your router bits and a hydraulic arbor for your profile tools at the same time. Perfectly centered and balanced.

Quick and easy tool changes independently for each tool, router bit vs. profile tool. The COMBO let you optimize your tool design for maximum performance and cost effectiveness.

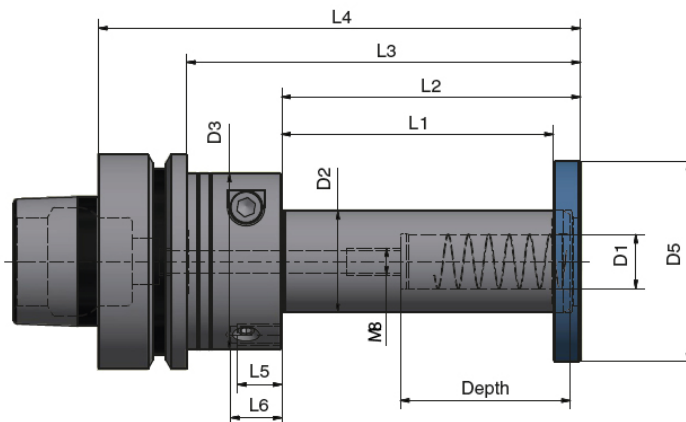
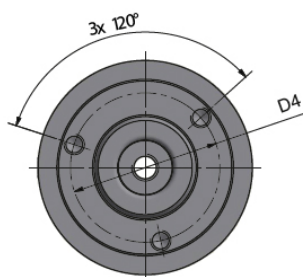

Technical Specification

HSK Size	Part no.	Item description	Dimensions, mm													Weight	
			D1	D2	D3	L1	L2	L3	L4	depth	D4	D5	L5	L6	Screw x3	kg	G 2.5 at rpm
63	704991	COMBO-16/30x20 HSK63F	16	30	48	20	28	56	82	50	40	54	8	10	M6x35	1.2	12 000
63	705806	COMBO-16/30x80 HSK63F	16	30	52	80	88	116	142	50	40	54	13	15	M6x100	1.6	12 000
63	705832	COMBO-20/35x80 HSK63F	20	35	52	80	88	116	142	52	44	59	13	15	M6x100	1.8	12 000
63 mod	705789	COMBO-16/30x20 HSK63F	16	30	48	20	28	56	82	50	40	54	8	10	M6x35	1.2	12 000

HSK Size	Part no.	Item description	Dimensions, inch													Weight	
			D1	D2	D3	L1	L2	L3	L4	depth	D4	D5	L5	L6	Screw x3	kg	G 2.5 at rpm
63	705825	COMBO-3/4"1 1/4"x80 HSK63F	0.750	1.250	2.047	3.150	3.465	4.567	5.591	1.969	1.732	2.323	0.512	0.591	M6x100	1.6	12 000

Router bit tool:

Recommended tolerance - h7
 Runout accuracy ≤ 0.004 mm at 2.5 x D1 (max. 50 mm)
 ≤ 0.00016 inch at 2.5x D1 (max. 1.969 inch)
 ≤ 0.007 mm at 2.5 x D1 at length L4 > 125 mm
 ≤ 0.00028 inch at 2.5x D1 at length L4 > 4.921 inch
 Center thread, M8x1.25, for axial length adjustment screw (screw not included)

Profile tool:

Recommended tolerance - H7
 Centering only.
 Security disc and 3 screws should always be mounted.
 Both Router bit and Profile tool has to be mounted before clamping.
 Security disc and 3 screws included in shipment.



Benefits and features

- World famous safety device
- Compact design
- Quick, safe and easy tool change
- Perfect runout and repeatability

ETP HYDRO-GRIP® G3 HSK 63F

HYDRO-GRIP type G3 is historically very tough but the new generation has an even more compact design. The hydraulic chuck is equipped with our well known built in safety device. The safety device prevents the tool from falling out when the chuck is not pressurized. Pressurizing is carried out with an allen T-wrench. The G3 chuck allows quick, safe and easy tool changes and perfect runout and repeatability.

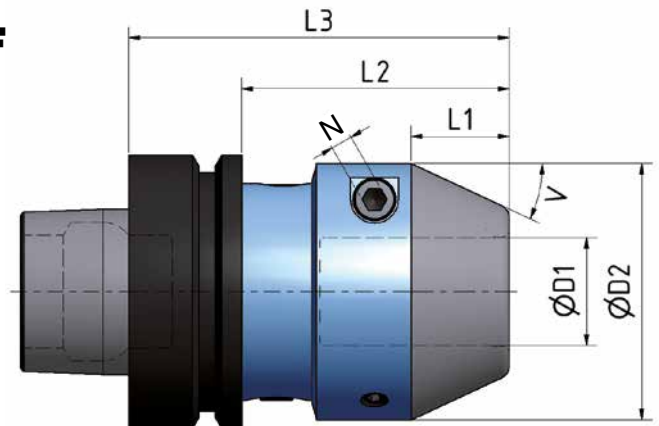

Technical specification ETP HYDRO-GRIP® G3 HSK 63F

Part.no	Item description	Dimensions, mm							Depth *	N	Max rpm
		D1	D2	L1	L2	L3	V				
53146	G3-12/HSK63F	12	45	3	42	68	70	24	5	25000	
53226	G3-16/HSK63F	16	48	9	48	74	45	30	5	25000	
53306	G3-20/HSK63F	20	52	15	54	80	30	36	5	25000	
53406	G3-25/HSK63F	25	59	22,5	61,5	87,5	25	43,5	5	25000	
665720	G3-3/8"/HSK63F	3/8"	45	3	42	68	70	24	5	25000	
54146	G3-1/2"/HSK63F	1/2"	45	4,5	43,5	69,5	65	25,5	5	25000	
54266	G3-3/4"/HSK63F	3/4"	52	13,5	52,5	78,5	35	34,5	5	25000	
54406	G3-1"/HSK63F	1"	59	22,5	61,5	87,5	25	43,5	5	25000	

*)= clamping length
 • The runout is measured at 3xD and the max runout is ≤ 0,006 mm (0.00024 inch).
 • The type G3 chuck is balanced to G2,5 at 25000 rpm.
 • A normally balanced chuck and tool can be used up to a max. speed of 25000 rpm.

● From stock

TOLERANCES

The type G3 chuck is designed and manufactured for a router bit shank with the tolerance g6 (h7). Transmittable torque for tools with tolerances:

Type	h6	h7	g6
D	Nm	Nm	Nm
12	25	15	15
16	80	60	60
20	185	125	125
25	400	300	300
3/8"	16	7	7
1/2"	25	15	15
3/4"	185	125	125
1"	400	300	300



PENCIL DESIGN

Benefits and features

- For drilling to finishing
- Pencil design enabling machining in deep cavities and complex components
- High clamping force



ETP HYDRO-GRIP® PENCIL HSK 63F

ETP HYDRO-GRIP® PENCIL is with its extreme slim design one of the most versatile holder on the market. An extensive range of standard dimensions and lengths optimizes your productivity when machining deep cavities and complex components.

- Runout accuracy: ≤ 0.004 mm at $2.5 \times d_{mt}$ (max. 50 mm)
 ≤ 0.00016 inch at $2.5 \times d_{mt}$ (max. 1.969 inch)
 ≤ 0.007 mm at $2.5 \times d_{mt}$ at length $l_1 > 125$ mm
 ≤ 0.00028 inch at $2.5 \times d_{mt}$ at length > 4.921 inch
- Balancing grade: G 2.5 at corresponding rpm - see in table below
- Tool shank h6 or h7 can be used
- Can be used with reduction sleeves, see page 15-16 for assortment

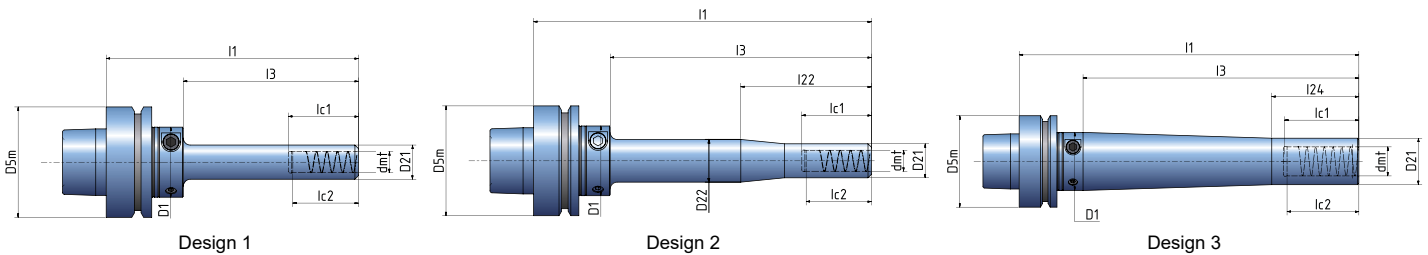

Technical specification ETP HYDRO-GRIP® PENCIL HSK 63F

Design	Part no.	Item description	Dimensions, mm											Max rpm	
			D_{5m}	d_{m1}	D_1	D_{21}	D_{22}	l_1	l_3	l_{21}	l_{22}	l_{24}	l_{c1}		l_{c2}
● 1	684400	HG PENCIL-6x50/HSK63F	63	6	40	12		94	50				40	30	25 000
● 1	684440	HG PENCIL-12x50/HSK63F	63	12	40	19,5		94	50				40	37	25 000
● 1	684450	HG PENCIL-12x100/HSK63F	63	12	40	19,5		144	100				40	37	15 000
● 2	684460	HG PENCIL-12x150/HSK63F	63	12	40	19,5	24,5	194	150	50	75		40	37	10 000
● 3	684490	HG PENCIL-20x110/HSK63F	63	20	40	32		154	110			60	52	49	20 000
● 3	684500	HG PENCIL-20x190/HSK63F	63	20	40	32		234	190			60	52	49	10 000
● 1	684540	HG PENCIL-1/2"x50/HSK63F	63	12,7	40	19,5		94	50				40	37	25 000
● 1	684550	HG PENCIL-1/2"x100/HSK63F	63	12,7	40	19,5		144	100				40	37	15 000
● 2	684560	HG PENCIL-1/2"x150/HSK63F	63	12,7	40	19,5	24,5	194	150	50	75		40	37	10 000
● 3	684590	HG PENCIL-3/4"x110/HSK63F	63	19,05	40	32		154	110			60	52	49	20 000
● 3	684600	HG PENCIL-3/4"x190/HSK63F	63	19,05	40	32		234	190			60	52	49	10 000

● From stock

l_1 = programming length



Hydraulic arbors



**New
extended
range**



ETP HYDRO-GRIP® GEW2 PowerLock

HYDRO-GRIP GEW2 is our hydraulic precision arbor for the **PowerLock system**. This combination will give you all the benefits from both the hydraulic centering function and the PowerLock system. The GEW2 arbor expands uniformly and is the ultimate centering and fastening solution for your tools.

The pressurizing is carried out by using an allen T-wrench and the mechanism is well protected from dust behind a sealed plug. Furthermore the arbor has a thread and a locking nut that makes the tool assembly extremely quick and easy.

Benefits and features

- Multiple tool assembly
- Easy to pressurize with an allen T-wrench
- Sealed dust plug
- Ultimate centering and fastening

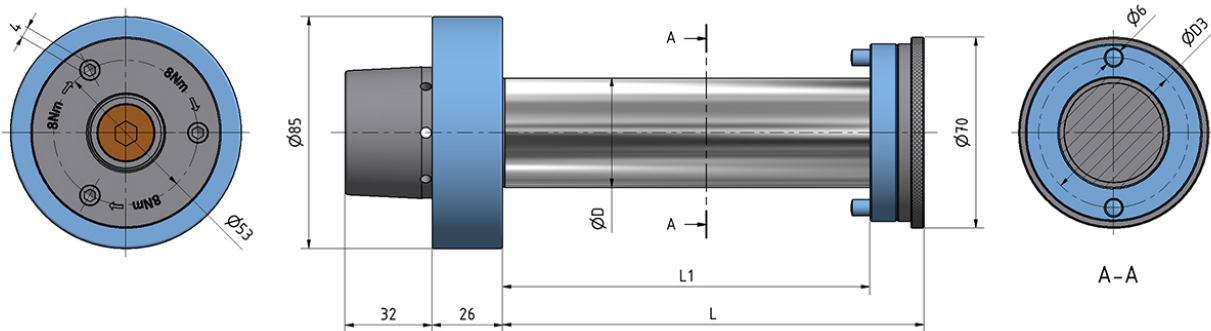

Technical specification ETP HYDRO-GRIP® GEW2

Part.no	Item description	Dimensions, mm					
		D	D3	L1	L	N1	N2
● 665960-55	GEW2 30x55	30	55	55	75	5	5
● 665960-100	GEW2 30x100	30	55	100	120	5	5
● 655390	GEW2 40x55	40	55	55	75	5	5
○ 704784	GEW2 40x80	40	55	80	100	8	8
● 655475	GEW2 40x135	40	55	135	155	8	8
● 665900-170	GEW2 40x170	40	55	170	190	8	8
● 655530	GEW2 40x240	40	55	240	260	8	8
● 666100-55	GEW2 50x55	50	62	55	75	8	8
● 666030-135	GEW2 50x135	50	62	135	155	8	8
● 666030-170	GEW2 50x170	50	62	170	190	8	8

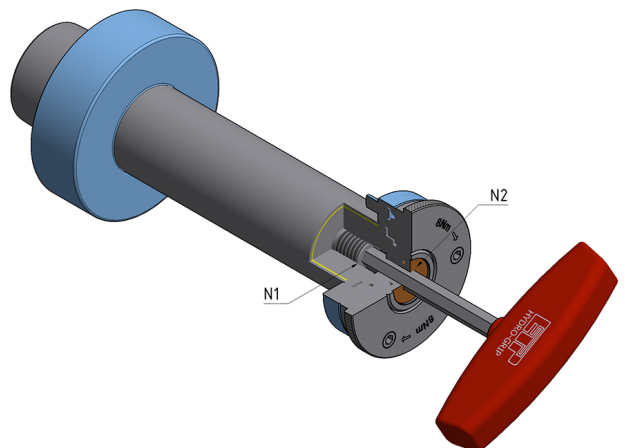

- From stock
- On request



Benefits and features

- Quick and precise tool assembly
- High performance and balance
- Redesigned safety ring in light metal
- Multiple tool attachment
- Adapted for three wing tools



ETP HYDRO-GRIP® GE2 HSK 63F

High performance units with perfect balance and runout for the tools. It can even be used in vertical mills, with or without tool changers.

The GE2 arbor allows quick and precise tool assembly and a high degree of flexibility. The arbor is adapted for easy attachment of three wing tools.

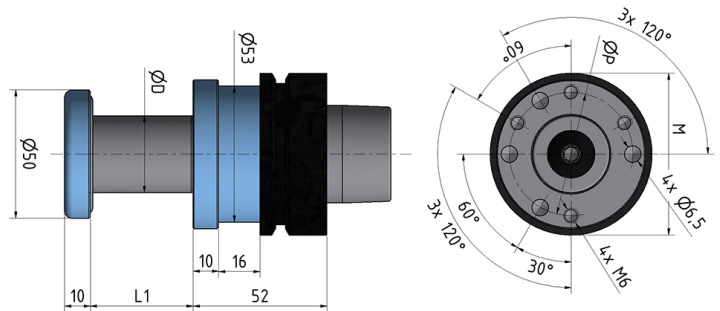

Technical specification ETP HYDRO-GRIP® GE2 HSK 63F

Part.no	Item description	D	L1	Dimensions, mm			
				M	P	N1	N2
667090	GE2-20x40/HSK 63F	20	40	53	32	6	8
667020	GE2-25x55/HSK 63F	25	55	53	40	6	8
666610	GE2-30x40/HSK 63F	30	40	58	48	6	8
666650	GE2-30x55/HSK 63F	30	55	58	48	6	8
666550	GE2-30x80/HSK 63F	30	80	58	48	6	8
666340	GE2-30x100/HSK 63F	30	100	58	48	6	8
704738	GE2-40x100/HSK 63F	40	100	67	56	6	8
666710	GE2-1"x40/HSK 63F	1"	40	53	40	6	8
666790	GE2-1"x55/HSK 63F	1"	55	53	40	6	8
666840	GE2-1"x80/HSK 63F	1"	80	53	40	6	8
666890	GE2-1 1/4"x40/HSK 63F	1 1/4"	40	58	48	6	8
666970	GE2-1 1/4"x55/HSK 63F	1 1/4"	55	58	48	6	8
667170	GE2-1 1/4"x100/HSK 63F	1 1/4"	100	63	48	6	8

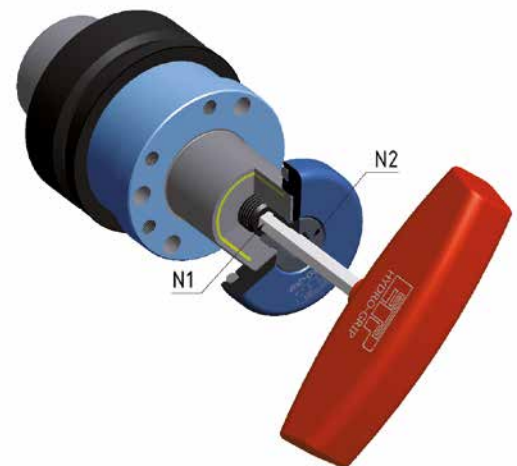

● From stock



Benefits and features

- Quick and precise tool assembly
- High performance and balance
- Easy interchange of tools between hydraulic- sleeves and arbors
- Combination with ETP CUBIT mini

ETP HYDRO-GRIP® GE2 HSK 63F mod.

This is the latest extension of our popular product line hydraulic arbors, designed for Homag through feed machines with HSK 63F modified motor spindle.

The new series include versions for single tools or tool sets with bore, and also units for adjustable tool sets. The later makes an excellent combination together with the adjustable unit, CUBIT mini.

The new products share the same benefits as all our hydraulic arbors, high performance due to excellent centering and balancing – the ultimate centering and fastening solution for your tools.

Existing tools or new tool sets can be switched between assembly on ETP HYDRO-GRIP type EI sleeves (used on machine spindles with hexagon) and the GE2 HSK 63F mod., which is suitable for flooring-, edge banding, double end tenoner machines.

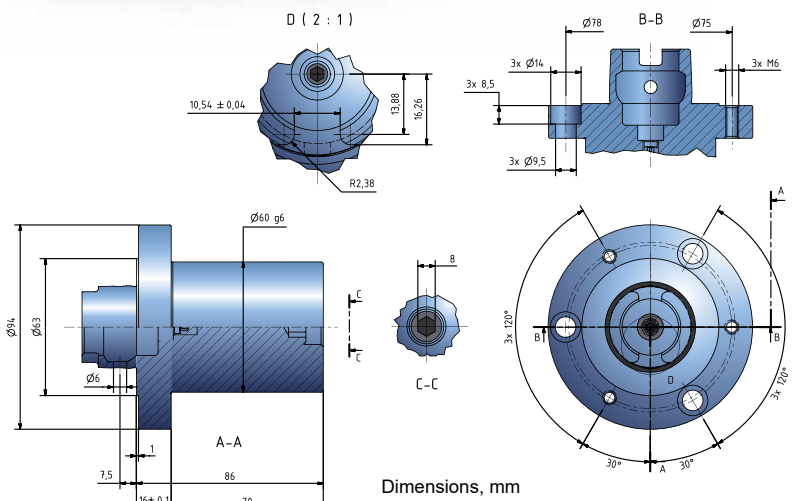

Technical specification

Part no.	Item description
662397	GE2-60x70/HSK63F mod.

The type GE2 HSK 63F mod. is designed for Homag through feed machines with HSK 63F modified motor spindle.

Recommended tool tolerance H7.

Pressurizing is carried out with an allen T-wrench, size 8 mm. Recommended tightening torque is 10 Nm.

Reduction Sleeves for ETP Toolholders

The reduction sleeves are designed to fit with the ETP Toolholders type G2 and PENCIL. They are specially suited for high precision clamping of cylindrical tool shanks.



Benefits and features

- **Accurate precision:**
High runout accuracy < 3 μm
- **High flexibility:**
Clamping of different tool shank diameters. 12, 20, 25 and 1/2", 3/4", 1"
- **Power increase:**
When using reduction sleeves the transmittable torque is increased

Outer-Ø of reduction sleeve corresponds to the type.
 HS12 = Ø 12 mm
 HS20 = Ø 20 mm
 HS25 = Ø 25 mm

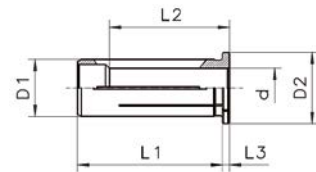

Reduction Sleeves mm to mm

Item description	d [mm]	Part no.	D1 [mm]	D2 [mm]	L1 [mm]	L2 [mm]	L3 [mm]
Reduction Sleeves HS 12							
● HS 12 / Ø 3.00	3.000	R1912.03000	12	16	40	29	4
● HS 12 / Ø 4.00	4.000	R1912.04000	12	16	40	29	4
● HS 12 / Ø 5.00	5.000	R1912.05000	12	16	40	29	4
● HS 12 / Ø 6.00	6.000	R1912.06000	12	16	40	36	4
○ HS 12 / Ø 7.00	7.000	R1912.07000	12	16	40	37	4
● HS 12 / Ø 8.00	8.000	R1912.08000	12	16	40	37	4
○ HS 12 / Ø 9.00	9.000	R1912.09000	12	16	40	37	4
● HS 12 / Ø 10.00	10.000	R1912.10000	12	16	40	40	4

Reduction Sleeves mm to mm

Item description	d [mm]	Part no.	D1 [mm]	D2 [mm]	L1 [mm]	L2 [mm]	L3 [mm]
Reduction Sleeves HS 20							
● HS 20 / Ø 3.00	3.000	R1920.03000	20	25	50	28	4
● HS 20 / Ø 4.00	4.000	R1920.04000	20	25	50	28	4
● HS 20 / Ø 5.00	5.000	R1920.05000	20	25	50	28	4
● HS 20 / Ø 6.00	6.000	R1920.06000	20	25	50	36	4
○ HS 20 / Ø 7.00	7.000	R1920.07000	20	25	50	38	4
● HS 20 / Ø 8.00	8.000	R1920.08000	20	25	50	37	4
○ HS 20 / Ø 9.00	9.000	R1920.09000	20	25	50	38	4
● HS 20 / Ø 10.00	10.000	R1920.10000	20	25	50	40	4
○ HS 20 / Ø 11.00	11.000	R1920.11000	20	25	50	40	4
● HS 20 / Ø 12.00	12.000	R1920.12000	20	25	50	45	4
○ HS 20 / Ø 13.00	13.000	R1920.13000	20	25	50	45	4
● HS 20 / Ø 14.00	14.000	R1920.14000	20	25	50	45	4
○ HS 20 / Ø 15.00	15.000	R1920.15000	20	25	50	45	4
● HS 20 / Ø 16.00	16.000	R1920.16000	20	25	50	48	4
● HS 20 / Ø 18.00	18.000	R1920.18000	20	25	50	48	4
Reduction Sleeves HS 25							
● HS 25 / Ø 3.00	3.000	R1925.03000	25	30	56	29	4
● HS 25 / Ø 4.00	4.000	R1925.04000	25	30	56	29	4
● HS 25 / Ø 5.00	5.000	R1925.05000	25	30	56	29	4
● HS 25 / Ø 6.00	6.000	R1925.06000	25	30	56	37	4
○ HS 25 / Ø 7.00	7.000	R1925.07000	25	30	56	37	4
● HS 25 / Ø 8.00	8.000	R1925.08000	25	30	56	37	4
○ HS 25 / Ø 9.00	9.000	R1925.09000	25	30	56	38	4
● HS 25 / Ø 10.00	10.000	R1925.10000	25	30	56	40	4
● HS 25 / Ø 12.00	12.000	R1925.12000	25	30	56	46	4
● HS 25 / Ø 14.00	14.000	R1925.14000	25	30	56	47	4
● HS 25 / Ø 16.00	16.000	R1925.16000	25	30	56	48	4
● HS 25 / Ø 18.00	18.000	R1925.18000	25	30	56	48	4
● HS 25 / Ø 20.00	20.000	R1925.20000	25	30	56	50	4

- ! Improper assembly can damage the concentricity of the reduction sleeve.
- ! Insert tools the full length of the reduction sleeve.
- ! Tool shank h6 or h7 can be used.
- ! Do not clamp reduction sleeve without a tool. Reduction Sleeve will be damaged.

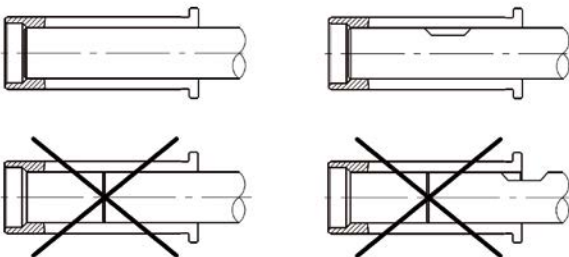

- From stock
- On request

ACCESSORIES

Reduction Sleeves inch to inch

Item description	d [inch"]	Part no.	D1 [inch"]	D2 [mm]	L1 [mm]	L2 [mm]	L3 [mm]
Reduction Sleeves HS 1/2"							
○ HS 1/2" / 1/8"	.1250"	R1913.03182	.500"	16	40	29	4
○ HS 1/2" / 3/16"	.1875"	R1913.04762	.500"	16	40	29	4
○ HS 1/2" / 1/4"	.2500"	R1913.06352	.500"	16	40	36	4
○ HS 1/2" / 5/16"	.3125"	R1913.07942	.500"	16	40	37	4
○ HS 1/2" / 3/8"	.3750"	R1913.09522	.500"	16	40	40	4
Reduction Sleeves HS 3/4"							
○ HS 3/4" / 1/8"	.1250"	R1919.03182	.750"	25	50	28	4
○ HS 3/4" / 3/16"	.1875"	R1919.04762	.750"	25	50	28	4
○ HS 3/4" / 1/4"	.2500"	R1919.06352	.750"	25	50	36	4
○ HS 3/4" / 5/16"	.3125"	R1919.07942	.750"	25	50	37	4
○ HS 3/4" / 3/8"	.3750"	R1919.09522	.750"	25	50	36	4
○ HS 3/4" / 7/16"	.4375"	R1919.11112	.750"	25	50	40	4
○ HS 3/4" / 1/2"	.5000"	R1919.12702	.750"	25	50	45	4
○ HS 3/4" / 9/16"	.5625"	R1919.14292	.750"	25	50	45	4
○ HS 3/4" / 5/8"	.6250"	R1919.15882	.750"	25	50	48	4
Reduction Sleeves HS 1"							
○ HS 1" / 1/8"	.1250"	R1926.03182	1.000"	30	56	29	4
○ HS 1" / 3/16"	.1875"	R1926.04762	1.000"	30	56	29	4
○ HS 1" / 1/4"	.2500"	R1926.06352	1.000"	30	56	37	4
○ HS 1" / 5/16"	.3125"	R1926.07942	1.000"	30	56	37	4
○ HS 1" / 3/8"	.3750"	R1926.09522	1.000"	30	56	38	4
○ HS 1" / 7/16"	.4375"	R1926.11112	1.000"	30	56	40	4
○ HS 1" / 1/2"	.5000"	R1926.12702	1.000"	30	56	46	4
○ HS 1" / 9/16"	.5625"	R1926.14292	1.000"	30	56	47	4
○ HS 1" / 5/8"	.6250"	R1926.15882	1.000"	30	56	48	4
○ HS 1" / 11/16"	.6875"	R1926.17462	1.000"	30	56	48	4
○ HS 1" / 3/4"	.7500"	R1926.19052	1.000"	30	56	48	4

Reduction Sleeves mm to inch

Item description	d [inch"]	Part no.	D1 [mm]	D2 [mm]	L1 [mm]	L2 [mm]	L3 [mm]
Reduction Sleeves HS 12							
○ HS 12 / 1/8"	.1250"	R1912.03181	12	16	40	29	4
○ HS 12 / 3/16"	.1875"	R1912.04761	12	16	40	29	4
○ HS 12 / 1/4"	.2500"	R1912.06351	12	16	40	29	4
○ HS 12 / 5/16"	.3125"	R1912.07941	12	16	40	36	4
○ HS 12 / 3/8"	.3750"	R1912.09521	12	16	40	37	4
Reduction Sleeves HS 20							
○ HS 20 / 1/8"	.1250"	R1920.03181	20	25	50	28	4
○ HS 20 / 3/16"	.1875"	R1920.04761	20	25	50	28	4
○ HS 20 / 1/4"	.2500"	R1920.06351	20	25	50	36	4
○ HS 20 / 5/16"	.3125"	R1920.07941	20	25	50	37	4
○ HS 20 / 3/8"	.3750"	R1920.09521	20	25	50	36	4
○ HS 20 / 7/16"	.4375"	R1920.11111	20	25	50	40	4
○ HS 20 / 1/2"	.5000"	R1920.12701	20	25	50	45	4
○ HS 20 / 9/16"	.5625"	R1920.14291	20	25	50	45	4
○ HS 20 / 5/8"	.6250"	R1920.15881	20	25	50	48	4
Reduction Sleeves HS 25							
○ HS 25 / 1/8"	.1250"	R1925.03181	25	30	56	29	4
○ HS 25 / 3/16"	.1875"	R1925.04761	25	30	56	29	4
○ HS 25 / 1/4"	.2500"	R1925.06351	25	30	56	37	4
○ HS 25 / 5/16"	.3125"	R1925.07941	25	30	56	37	4
○ HS 25 / 3/8"	.3750"	R1925.09521	25	30	56	38	4
○ HS 25 / 7/16"	.4375"	R1925.11111	25	30	56	40	4
○ HS 25 / 1/2"	.5000"	R1925.12701	25	30	56	46	4
○ HS 25 / 9/16"	.5625"	R1925.14291	25	30	56	47	4
○ HS 25 / 5/8"	.6250"	R1925.15881	25	30	56	48	4
○ HS 25 / 11/16"	.6875"	R1925.17461	25	30	56	48	4
○ HS 25 / 3/4"	.7500"	R1925.19051	25	30	56	48	4
○ HS 25 / 13/16"	.8125"	R1925.20631	25	30	56	50	4

HYDRO-GRIP® Torque Wrench

Use torque wrench to ensure correct tightening independent on user. Should be used with all HYDRO-GRIP® holders.



Item description	Tightening torque:	Part no.
● Torque wrench 6 Nm 5 mm Hex	6 Nm	19050
● Torque wrench 10 Nm 5 mm Hex	10 Nm	19052

Extractor

Item description	Part no.	For Sizes	A [mm]	B [mm]
● EHS 12 - 1/2"	E7321.12000	HS 12	24.6	100
● EHS 20 - 3/4"	E7321.20000	HS 20	38.0	160
● EHS 25 - 1"	E7321.25000	HS 25	51.0	180

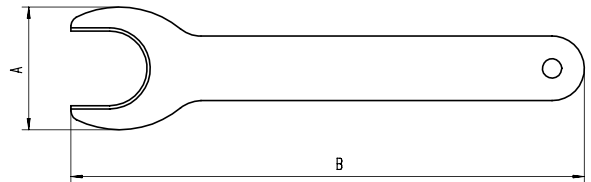

The extractor helps to remove the reduction sleeve from the toolholder.

- From stock
- On request



Box 1120, SE-581 11 Linköping, Sweden
Tel. +46 (0)13 24 71 00
E-mail: info@etp.se, Internet: www.etp.se