

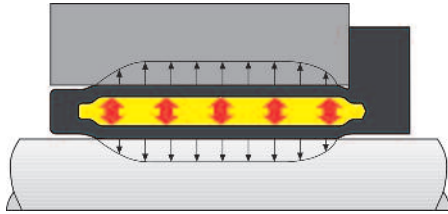

Hydraulic hub-shaft connections

Quick, easy and precise



Pascal discovered the principle

We put it to work

The scientist Blaise Pascal formulated the principle of pressure propagation in liquids many years ago.

ETP has explored the many positive qualities in this principle, developed it further and applied it to hub-shaft connections.

A hydraulic pressure medium confined in a double-walled sleeve is pressurized, with screws or with an external pump. The double-walled sleeve expands uniformly and gives an even contact pressure against shaft and hub.

With increasing requirements on down sizing of machines, better runout/balance, increased machine speeds, shorter downtime for service and increased precision, ETP hydraulic hub-shaft connections are chosen for more and more designs.



ETP – The company and the products

ETP Transmission AB have developed and manufactured hydraulic hub-shaft connections for more than 40 years, which are sold under the trademark ETP®.

The company has built up a unique world wide knowledge and leading position within the hydraulic fastening and centering field.

Continuous development with customers, where ETP contribute with a wide application knowledge and calculation assistance, has resulted in a steady flow of new products, both standard and customized designs.

Authorized representatives with stock and high levels of technical knowledge are present in each country in Western Europe, North America, China, Japan, Australia, New Zealand, South-Africa, India and Southeast Asia.



Precision connection



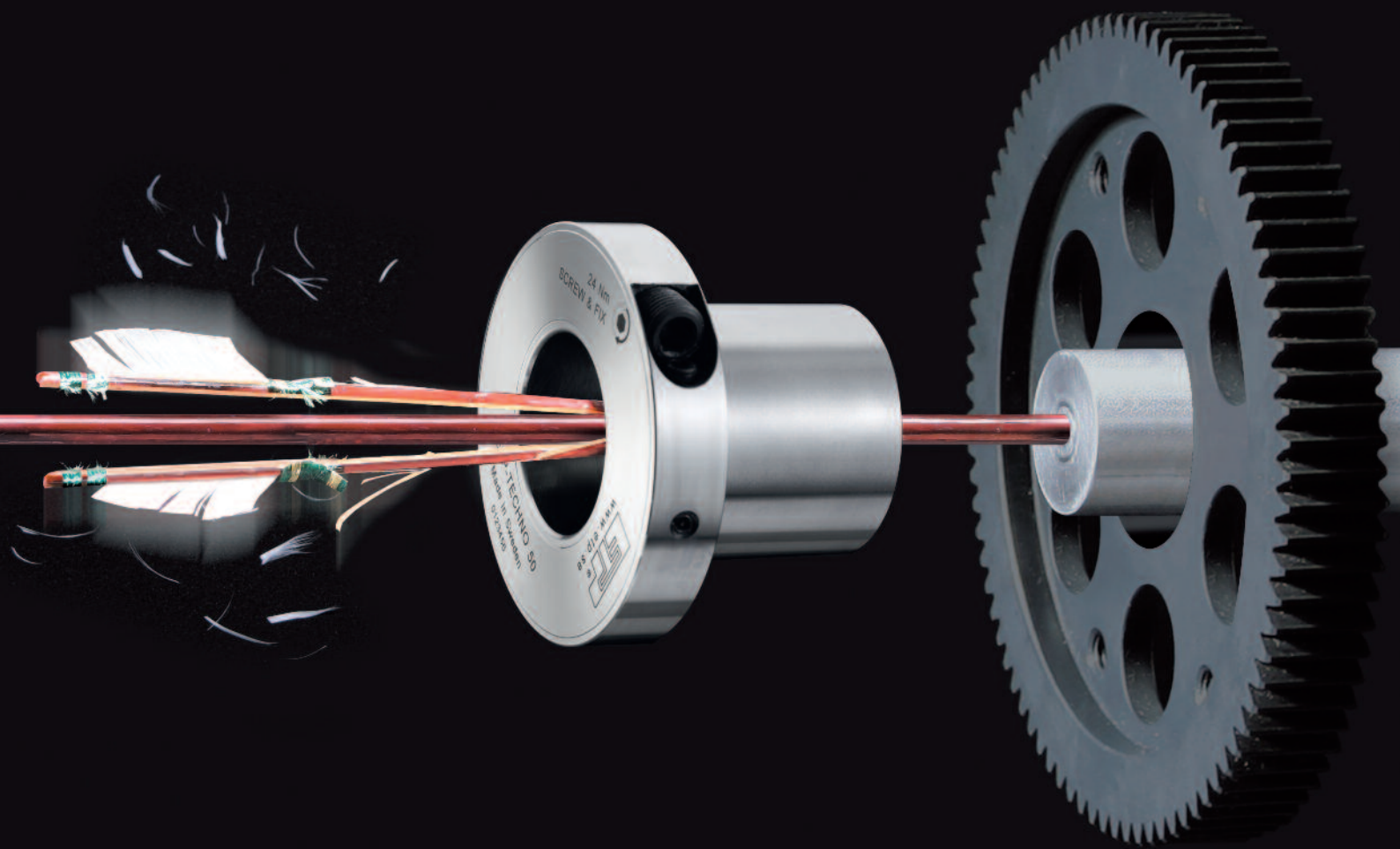

ETP hub-shaft connections



ETP hub-shaft connections are today regarded as the natural range to choose from for professional machine design. They represent the optimal cost/performance ratio and are available in a number of variants. They operate according to either the hydraulic or hydromechanical principle, which gives unique advantages when designing, in operation and when dismantling.

The hydraulic ETP principle

ETP-EXPRESS, ETP-EXPRESS R, ETP-POWER and ETP-TECHNO are all mounted very quick and simple by tightening of only **one** screw. ETP-EXPRESS R is made of stainless steel. ETP-TECHNO is used when frequent mounting is important and for extremely good concentricity. ETP-POWER for high radial loads.

All products consist of a double-walled hardened steel sleeve, filled with a pressure medium. In the flange there are **one** screw and a piston with seals for the pressure setting.

All work according to the hydraulic principle: when tightening the screw an even and moderately high surface pressure is created against shaft and hub. Mounting and dismantling are done in less than 10 seconds.

The hydraulic principle gives advantages important for today's modern machines. With increased requirements for compact designs, better concentricity/balance at increased machine speeds, shorter downtime for service and increased precision, ETP products are chosen for more and more designs.

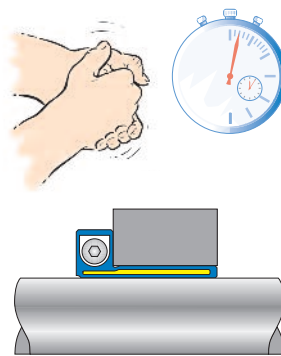

Quick mounting.

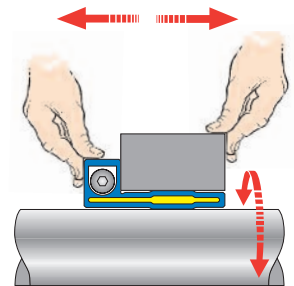

Easy and accurate to position.

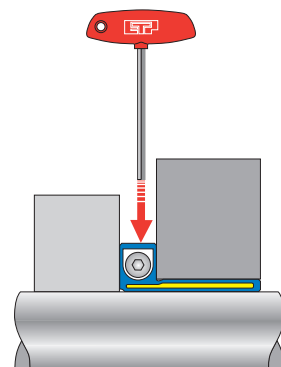

Saves space along the shaft.

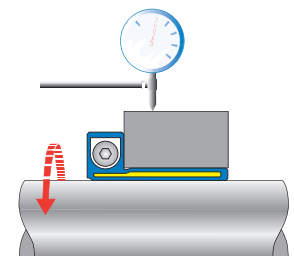

Good runout.

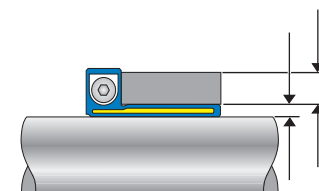

Small built-in dimensions.

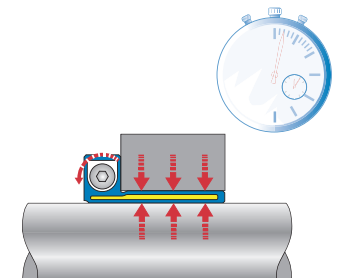

Quick dismantling.



The hydromechanical ETP principle

ETP-HYLOC is mounted quickly and easily, even for big shafts, with a hydraulic pump. The hydraulics makes the mounting simple and gives a good runout. When the connection is mounted it is mechanically self locked.

The hydromechanical ETP principle is specially suitable for high torque, high radial forces and for big shafts.

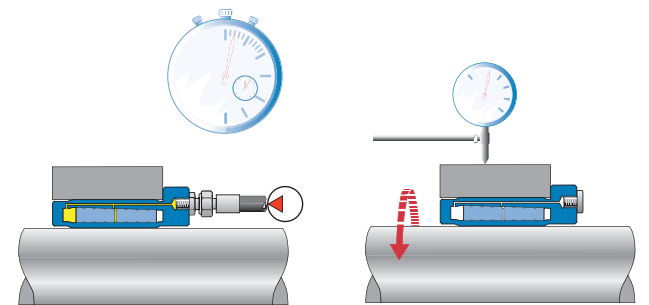

Quick mounting and dismantling.

Good runout.

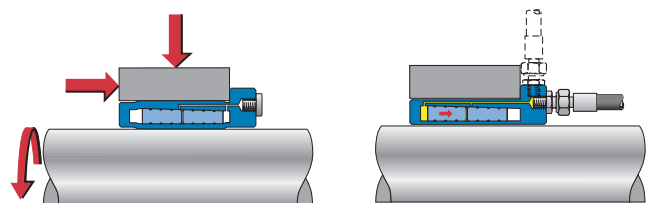

High torque, radial and axial forces.

Connection axial and/or radial.

Choose the ETP-connection that suits you best

ETP single screw product range



ETP-EXPRESS

ETP-TECHNO

ETP-POWER

Benefits and features

Number of mountings

● ●

● ● ● ●

●

Compact

● ● ● ●

● ●

●

Runout

● ●

● ● ● ●

●

Temperature range

● ●

● ● ● ●

●

Radial loads

●

● ●

● ● ● ●

Sealing system

●

● ● ● ●

●

● Good ●● Better ●●● Best

Get the most out of your hub-shaft connections - Download our ETP Calc App

The ETP Calc App is designed to help engineers and users of our hydraulic hub-shaft connections to quickly and easily check their application based on real parameters.

ETP Calc is simple to use! Just choose your input values from the drop menus and the result will be shown.

You can also save, print or e-mail your finished calculations.

Available for iPhone and iPad at App Store, or visit www.etp.se to use our online calculation application.

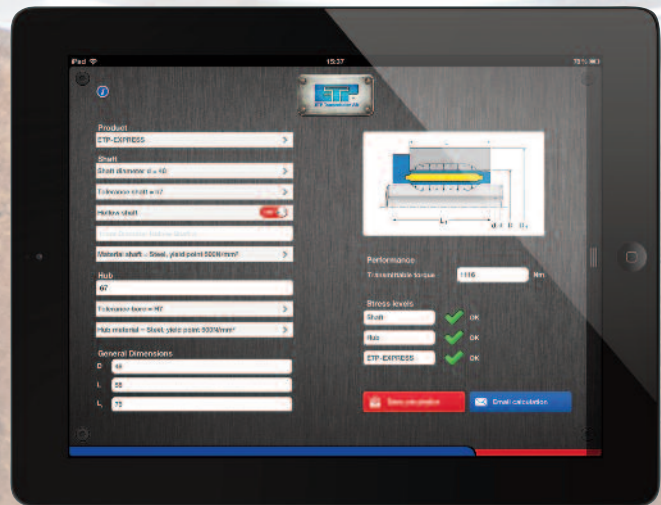

Key to symbols



Quick and easy mounting with just ONE pressure screw.



Mounting with a hydraulic pump.

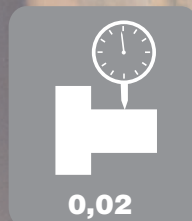

Runout accuracy mm.

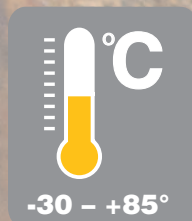

Operating temperature range.

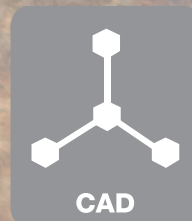

Cad symbols 2D/ 3D available for download at www.etp.se or www.etp.solidcomponents.com



Stainless steel version.

Table of content

Page



ETP-EXPRESS®

For fast mounting and compact design.

8-13



ETP-EXPRESS® R

Corrosion resistant and easy to clean.

14-17



ETP-TECHNO®

High precision and frequent mounting.

18-21



ETP-POWER®

Fast mounting and high radial loads.

22-25



ETP-CLASSIC® incl. type R

Competitive connection for normal needs.

26-29



ETP-MINI® incl. type R

Quick compact fastening of small components.

30-31



ETP-HYLOC®

For heavy loads and quick mounting.

32-35

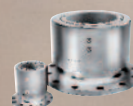

ETP-HYCON®

High torque shaft-shaft and shaft-flange couplings.

36-39

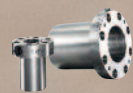

ETP-OCTOPUS®

For fast, frequent and accurate linear positioning.

40-43



ETP customized designs

Based on the customers requirements.

44-49



Accessories

Torque wrenches and pumps.

Connections and screws.

Friction increasing methods.

50-51

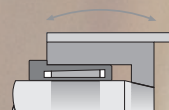

Technical information/ Design tips

52-55

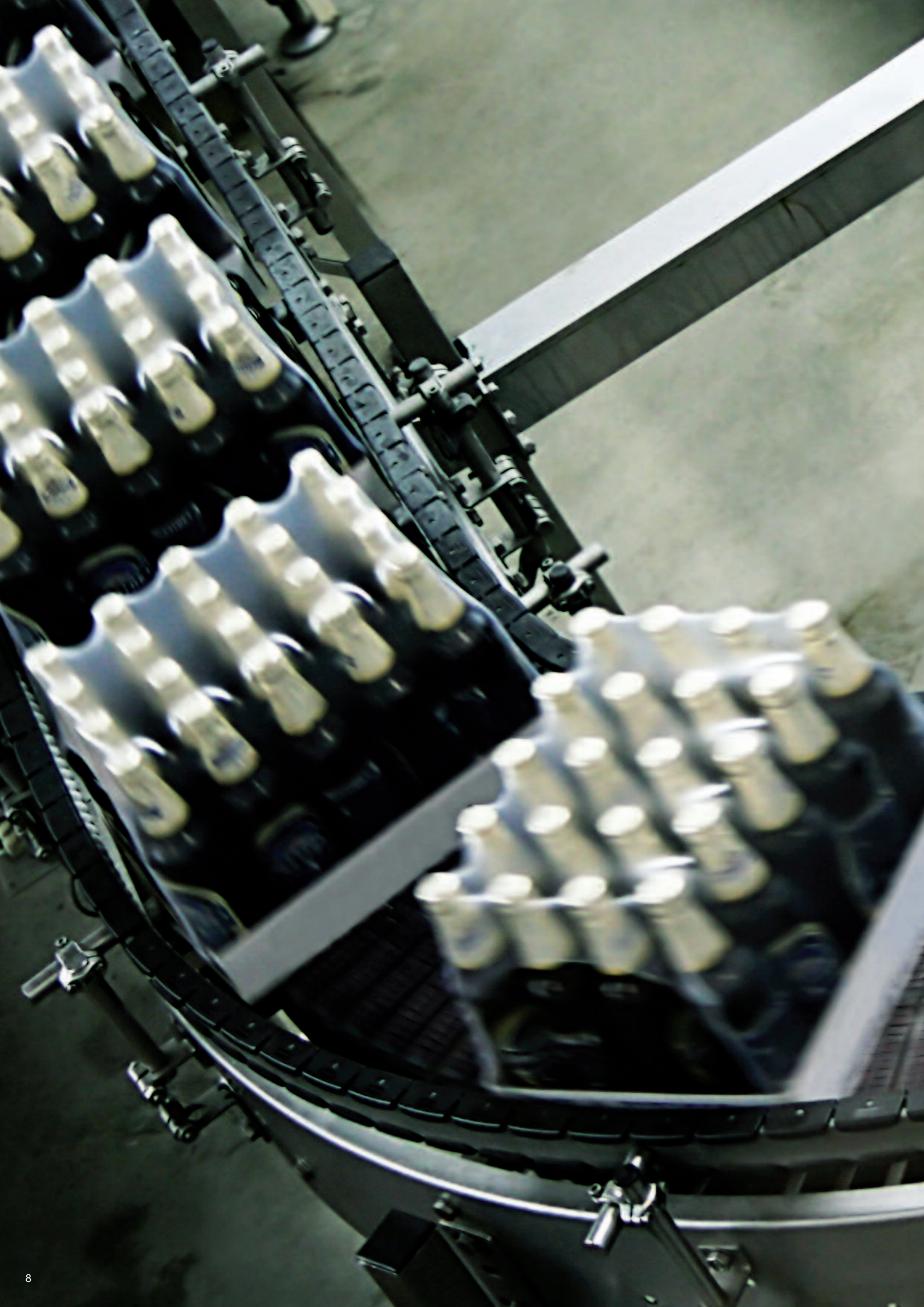

ETP-EXPRESS®

For fast mounting
and compact design

ETP-EXPRESS is a hydraulic connection which has only one screw for pressurising. It is especially suitable for repositioning of the hub fast and accurately. The screw is tightened in the radial direction, this means no space is used along the shaft for mounting tools. Other components can be mounted on the shaft all the way up to the flange. ETP-EXPRESS has extremely small built-in dimensions which makes a compact design possible.

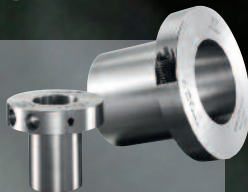

Easy to position and adjust with one screw

In this handling and packaging machine for newspapers after printing, ETP-EXPRESS of various sizes are used. The final adjustment of levers and timing pulleys in order to get all parts synchronised is facilitated, as only one screw needs to be loosened/tightened. The radial access to the screw permits a compact design. Also hubs of aluminium and cast iron can be used because of the moderate surface pressure.

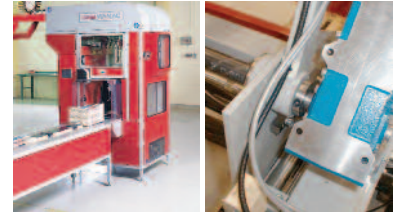

Good runout and radial accessibility

This unit belongs to a production line which inserts enclosures into newspapers after printing and folding. A number of star-shaped sorting wheels are fastened after each other along the shaft with ETP-EXPRESS. Tightening with radial access was a necessity for this compact design. Other requirements were good runout, low axial concentricity and a minimum of vibration.

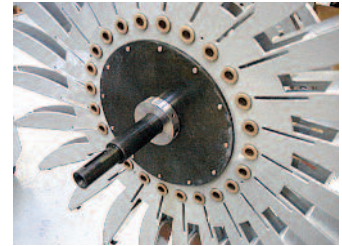

Thin hub

The shaft for the timing drive in this packaging machine is relatively large, but the outer diameter for the timing pulley must be kept to a minimum. ETP-EXPRESS was chosen because of its small outer diameter and moderate surface pressure. The radial tightening also saved space along the shaft.

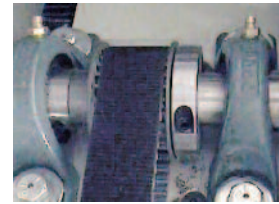

Axial positioning along the shaft and low tightening torque

Previously a universal joint with splines was used in a test bench, which caused backlash and vibrations. After the change to a disc coupling with integrated ETP-EXPRESS these problems were solved, at the same time the total length of the coupling can easily and quickly be adjusted. With frequent adjustment having a single screw with low tightening torque is a great help.

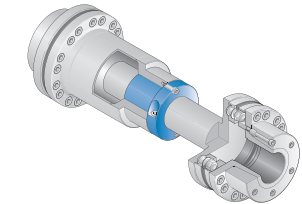

Adjustability with only one screw

For these two synchronized chain drives in this spring making machine, ETP-EXPRESS is used for fastening of the pulleys. The chains wear at different rates and need regular adjustment that can be done quickly. The single radially accessible screw makes this easy.



No axial movement

Before each press operation an accurate position needs to be established. ETP-EXPRESS is used as the position along the shaft will not change when pressurised, the sleeves are tensioned only in the radial direction into contact with shaft and hub. The radial access was another necessity for this design.



Shorter assembly times

In a production line for PET bottles, ETP-EXPRESS is used to fix without backlash a torque limiter. If the limiter should slip unintentionally it will lead to downtime. During assembly the whole machine is pretensioned for no backlash. In this setting the whole unit is locked by tightening of only one screw. This "one screw principle" saves operator time during assembly, which leads to increased productivity.

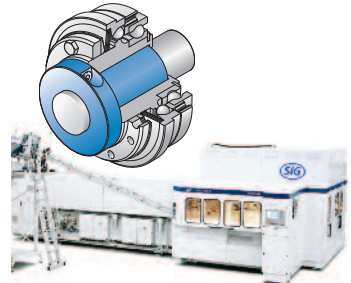

Backlash free

This metal disc coupling sits in a drive for a paper machine. Instead of a keyway ETP-EXPRESS is used, consequently the problems with backlash and fretting corrosion have been eliminated and the mounting made easier.



Radial tightening

When fastening the drive wheels for a number of synchronised transport chains, often the space along the shaft is limited. In this case it was solved with ETP-EXPRESS, as only radial access to the screw is needed. Only one screw per connection makes necessary adjustments after assembly easier.



Synchronisation

In transport equipment often a number of drives needs to be synchronised. In this machine ETP-EXPRESS is used for this purpose for both the chain and timing pulley drives. The simple mounting and radial access were the reasons. The compact built-in dimensions are also important for the timing pulleys



Quick changes/adjustments

In this feeding mechanism for a steel plate punching machine several ETP-EXPRESS are used. The easy pressure setting of ETP-EXPRESS makes the change over to another size steel plate quick and accurate.



Exact and reliable positioning/adjustment

In friction welding of aluminium profiles a number of welding surfaces are pressed together under precise conditions. The locking levers fastened with ETP-EXPRESS perform this task. When adjusting to other profiles, a large number of levers have to be loosened, repositioned and accurately fixed again. The use of ETP-EXPRESS has reduced the downtime to a minimum. The radial tightening allows for a compact design.



Quick changes

These feeding rollers are fastened at both ends with ETP-EXPRESS, which needs a minimum of space along the shaft and facilitates dismantling/mounting for service and maintenance.

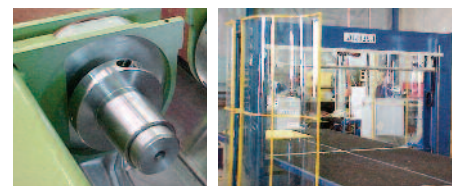

Backlash free

For this press ETP-EXPRESS was chosen for fastening the levers which steer the accurate feeding mechanism. No backlash and good repeatability were the important criterias when selecting the connection. The adjustment during assembly of the machine was at the same time made easier.



Exact positioning

During airplane assembly, a number of flexible fixtures, are used to support the fuselage. The fixture, can through the six arm design (hexa pod), be adjusted into any position required. ETP-EXPRESS, fastens each arm. This enables a completely stepless and precise length adjustment and positioning of the fixture. As no axial displacement occurs, the adjusted position will be maintained with needed precision for the fuselage assembly.

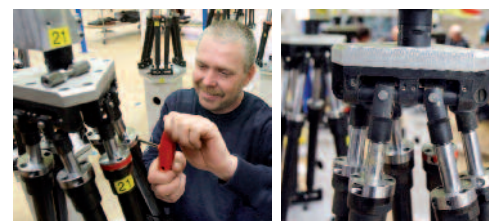

Easy adjustment

In this flow pack type packaging machine ETP-EXPRESS fastens a number of timing pulleys mounted on the drives. The radial tightening allows for a compact design and easy synchronisation and adjustment.

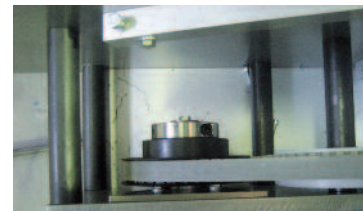

Quick mounting

In this digital printer sub system, for improving paper quality before printing, ETP-EXPRESS was chosen for its quick mounting and space saving features. The small built-in dimensions gives a compact and optimised design.



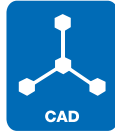

For fast mounting

- BENEFITS & FEATURES**
- Extremely fast mounting/dismantling with only ONE screw.
 - Extremely small built-in dimensions.
 - Radial tightening of the screw saves space along the shaft.
 - Accurate positioning, no axial movement when mounting.
 - Good concentricity, also after several mountings.

ETP-EXPRESS®

ETP-EXPRESS is available as standard for shafts 15-100 mm, also imperial. Runout $\leq 0,02$ mm. Number of mountings 500 - 2 000 (size dependent). The extremely thin built-in dimensions allows for a compact design with low weight and inertia.

Construction
ETP-EXPRESS is a hydraulic connection which consists of a double-walled hardened steel sleeve filled with a pressure medium and a flange. The flange part contains screw and piston with seals to maintain pressure.

Operation
When the pressure screw is tightened, the double-walled sleeve expands uniformly against shaft and hub and creates a rigid joint. Dismantling is done by loosening the screw. ETP-EXPRESS returns to its original dimensions and can easily be dismantled.

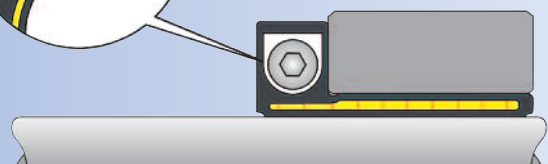
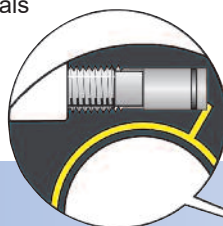

When the pressure screw is tightened to the recommended tightening torque, the piston has reached the bottom of the bore. ETP-EXPRESS has created a uniform surface pressure against the shaft and hub.

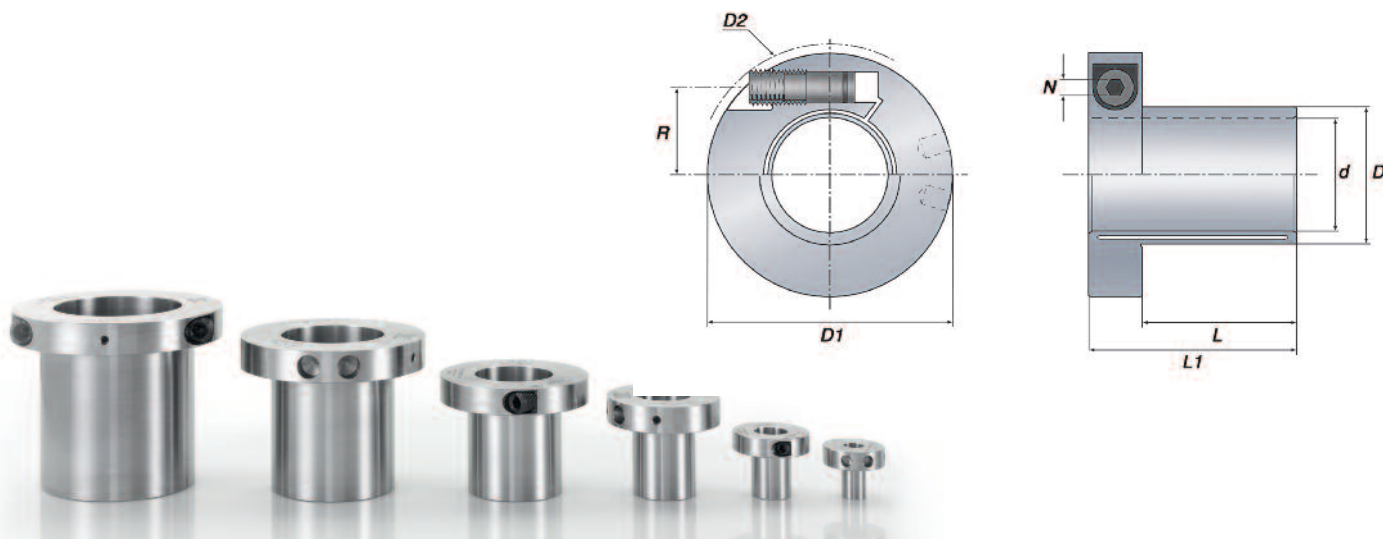

Technical Specification ETP-EXPRESS

ETP-EXPRESS	Dimensions						Transmittable			Screws DIN 915, 12.9				Polar moment of inertia J $\text{kgm}^2 \cdot 10^{-3}$	Weight kg
	d mm	D mm	D ₁ mm	D ₂ * mm	L mm	L ₁ mm	torque T Nm	axial force F _A kN	radial force F _R kN	Dim.	R mm	N mm	Tt Nm		
● 15	15	18	46	48,9	25	39	46	5,1	0,5	M10	15,1	5	5	0,04	0,16
○ 5/8"	15,875	19	47	49,8	26	40	53	5,5	0,5	M10	15,6	5	5	0,05	0,17
● 19	19	23	50,5	53,0	28	42	85	7,3	1	M10	17,4	5	5	0,06	0,20
○ 3/4"	19,05	23	50,5	53,0	28	42	85	7,3	1	M10	17,4	5	5	0,06	0,20
● 20	20	24	51,5	54,1	30	44	110	9,1	1	M10	18	5	5	0,07	0,21
○ 22	22	27	55,5	60,5	32	46	130	9,6	1,2	M10	19,3	5	5	0,10	0,25
● 7/8"	22,225	27	55,5	60,5	32	46	130	9,6	1,2	M10	19,3	5	5	0,10	0,25
● 24	24	29	57,5	62,3	33	47	190	13	1,4	M10	20,3	5	5	0,11	0,27
● 25	25	30	58	62,9	35	49	230	15	1,5	M10	20,8	5	5	0,12	0,27
● 1"	25,4	31	59	63,8	35	49	190	12	1,5	M10	21,2	5	5	0,13	0,29
● 28	28	34	63	69,6	38	52	280	16	1,8	M10	22,6	5	5	0,17	0,34
○ 1 1/8"	28,575	35	63,5	70,1	39	53	290	16	1,8	M10	23	5	5	0,18	0,35
● 30	30	36	64,5	71,0	40	54	380	21	2	M10	23,6	5	5	0,19	0,35
○ 1 1/4"	31,75	39	68,5	77,7	42	56	430	22	2,2	M10	24,8	5	5	0,25	0,42
● 32	32	39	68,5	77,7	42	56	440	22	2,2	M10	24,8	5	5	0,25	0,42
○ 1 3/8"	34,925	42	73	85,1	45	59	640	30	2,5	M10	26,4	5	5	0,32	0,48
● 35	35	42	73	85,1	45	59	640	30	2,5	M10	26,4	5	5	0,32	0,48
○ 1 7/16"	36,5125	44	74,5	86,6	48	62	740	33	2,6	M10	27,3	5	5	0,36	0,52
● 38	38	46	84,5	89,5	52	72	890	38	2,8	M16	31	8	21	0,76	0,84
● 1 1/2"	38,1	46	84,5	89,5	52	72	890	38	2,8	M16	31	8	21	0,76	0,84
● 40	40	48	86,5	91,2	55	75	1100	45	3	M16	32	8	21	0,84	0,88
● 42	42	51	89	93,5	56	76	1100	43	3,2	M16	33,2	8	21	0,97	0,96
○ 1 3/4"	44,45	54	93	100,3	58	78	1400	51	3,5	M16	34,8	8	21	1,20	1,10
● 45	45	54	93	100,3	58	78	1400	51	3,5	M16	34,8	8	21	1,17	1,05
○ 48	48	59	97	103,8	59	79	1700	57	4	M16	36,8	8	21	1,46	1,21
○ 1 15/16"	49,2125	60	98,5	105,1	60	80	1900	63	4,3	M16	37,5	8	21	1,57	1,27
● 50	50	60	98,5	105,1	60	80	1900	63	4,5	M16	37,5	8	21	1,52	1,20
○ 2"	50,8	61	101,5	111,8	60	80	1900	62	4,5	M16	38	8	21	1,72	1,28
● 55	55	67	106	115,9	65	85	2400	71	5	M16	40,5	8	21	2,18	1,50
● 60	60	73	115,5	132,7	70	90	3300	90	5,3	M16	43,3	8	21	3,17	1,85
○ 2 1/2"	63,5	77	119	134,6	73	93	4000	105	5,4	M16	45,1	8	21	3,74	2,04
○ 65	65	79	120,5	137	75	95	4400	112	5,6	M16	46,1	8	21	4,1	2,13
○ 70	70	85	135,5	153,9	85	109	5600	130	6,4	M20	50,8	10	39	7,12	3,04
○ 3"	76,2	92	141,5	157,8	91	115	7500	160	7	M20	54,1	10	39	9,01	3,48
○ 80	80	97	145,5	162,6	95	119	8700	180	7,5	M20	56,3	10	39	10,35	3,75
○ 90	90	109	155,5	171,7	105	129	12000	220	8,6	2 x M20**	61,8	10	39	15,20	4,80
○ 100	100	121	166	181,0	115	139	17000	280	9,7	2 x M20**	67,3	10	39	21,90	5,90

T= Transmittable torque when axial force is 0. } When the screw/screws is tightened to Tt
 FA=Transmittable axial force when torque is 0.
 FR=Max transmittable radial force at continuous operation.
 Max allowed bending torque: 5% of transmittable torque T.

● From stock ○ on request

Tt= Recommended tightening torque for the screw/screws.
 Further tightening does not increase the pressure.
 *) D2 is valid before mounting.
 **) Pressure screws positioned in the same direction.
 Dimensions subject to alterations without notice.

TOLERANCES

Shaft h7 for d =15 mm.
 Shaft k6-h7 for d = 19, 22, 24, 28, 32, 38, 42, 48, 55 mm.
 Shaft h8 for all other dimensions d.
 Hub H7.

For further information see section Technical information/Design tips, page xx.

Type of torque

Transmittable torque, T, is for static load.
 If the load is alternating or pulsating torque, reduce the transmittable torque, T, with the following factors: (factor x T).
 Alternating: 0,5 x T.
 Pulsating: 0,6 x T.

ETP-EXPRESS® R

Corrosion resistant
and easy to clean

The demand from the food and process industries is increasing for stainless steel hub-shaft connections. The most common sizes of the hydraulic connection ETP-EXPRESS are available in stainless steel. The flat flange design allows for easy cleaning, essential within food processing.

Also the pressure medium and screw lubricant are approved for use in the food industry.



Small built-in dimensions and one radial screw

In this cleaning system for workpieces in the automobile industry, ETP-EXPRESS R is used for fastening of the brushes. The minimal built-in dimensions, radial tightening, good runout (less vibrations), moderate surface pressure with thin hubs (a bearing outside the hub) and resistance to fretting corrosion were important factors. Also the quick change of brushes was a benefit.

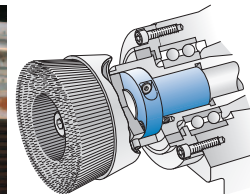

Food approved

A through going shaft in a gearbox is locked in both ends with ETP-EXPRESS R. The gearbox drives a mixer for food. Also the pump wheel in the mixer is locked with ETP-EXPRESS R, which fulfills the requirements to be approved for use in food environment. The good corrosion resistance, the quick mounting and ease of cleaning are appreciated features.



Frequent mounting, sealing function

In this "column" for manufacturing of medicines ETP-EXPRESS R is used to make sure that the piston is locked in an exact position vertically. The design is compact with a thin hub and a hollow shaft, at the same time the moderate and even surface pressure in both directions have a sealing function. Frequent adjustments, approval to be used in food environment, ease of cleaning are other important factors.

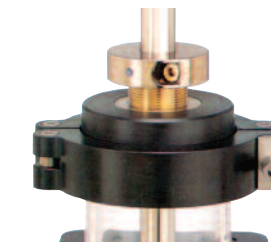

Exact and quick axial positioning

In this test machine for static and dynamic strength of for example skeleton parts, ETP-EXPRESS R is used for adjustment and locking of the lower shaft to which the parts are fixed. Positioning is important and is made easily as no axial movement takes place when the screw is tightened. Change of test specimen is made quickly as only one screw has to be operated. The surface of the shaft will not be damaged, even when frequently mounted, because of the even and moderate surface pressure.



Ease of mounting/adjustment

Two parallel chains drive this packaging machine for food. Adjustment of the chains, relative each other, and location of the chain hubs in position along the shafts are made easy when ETP-EXPRESS R is used. Adjustments are easily done later as only one screw needs to be loosened/ tightened.

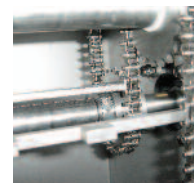

Accurate positioning, adjustments, good runout

The gears in this food machine are accurately adjusted during assembly with ETP-EXPRESS R to avoid backlash and noise. After a certain time wear makes adjustment necessary, this is done easily as only one screw needs to be loosened/ tightened. Also the good runout helps to reduce the noise level and vibrations.

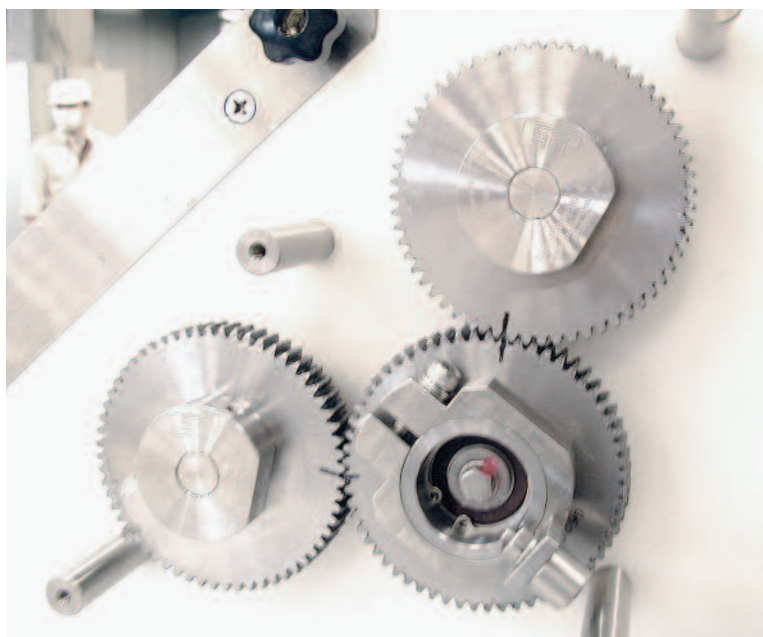



ETP-EXPRESS R is available as standard for shafts 15-80 mm, also imperial. Runout $\leq 0,02$ mm. Number of mountings 200 – 800 (size dependent). The extremely thin built-in dimensions allows for a compact design with low weight and inertia.

Construction

ETP-EXPRESS R is a hydraulic connection which consists of a double-walled hardened stainless steel sleeve filled with a pressure medium, and a flange. The flange part contains a stainless screw and piston with seals to maintain pressure.

Operation

When the pressure screw is tightened the double-walled sleeve expands uniformly against shaft and hub and creates a rigid joint. Dismantling is done by loosening the screw. ETP-EXPRESS R returns to its original dimensions and can easily be dismantled.

BENEFITS & FEATURES

- ETP-EXPRESS R have the same benefits and features as ETP-EXPRESS.
- All parts exposed to the environment are made of stainless steel.
- Flat flange design allows for easy cleaning.
- Pressure medium and screw lubricant are food approved.

When the pressure screw is tightened to the recommended tightening torque, the piston has reached the bottom of the bore. ETP-EXPRESS R has created a uniform surface pressure against the shaft and hub.

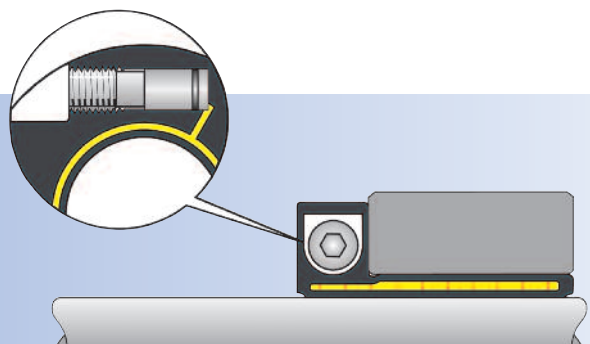

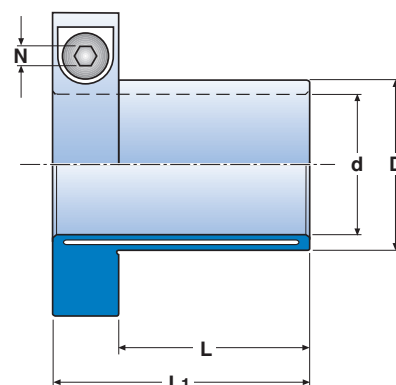
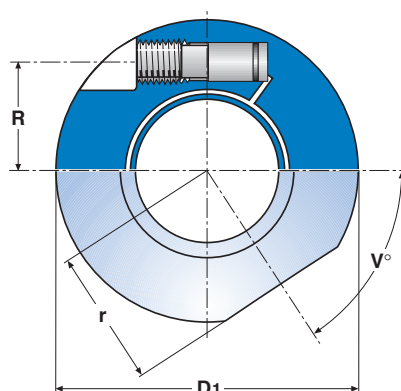

Notation ETP-EXPRESS R-XX

Technical Specification ETP-EXPRESS R

ETP-EXPRESS	Dimensions								Transmittable			Screws DIN 915, 12.9				Polar moment of inertia J kgm ² · 10 ⁻³	Weight kg
	d mm	D mm	D ₁ mm	D ₂ * mm	L mm	L ₁ mm	r mm	v°	T Nm	F _A kN	F _R kN	Dim.	R mm	N mm	Tt Nm		
● R-15	15	18	46	48,9	25	39	19,9	53	46	5,1	0,5	M10	15,1	5	5	0,04	0,16
○ R-5/8"	15,875	19	47	49,8	26	40	20,3	54	53	5,5	0,5	M10	15,6	5	5	0,05	0,17
○ R-3/4"	19,05	23	50,5	53,0	28	42	21,9	55	85	7,3	1	M10	17,4	5	5	0,06	0,20
● R-20	20	24	51,5	54,1	30	44	22,6	56	110	9,1	1	M10	18	5	5	0,07	0,21
○ R-7/8"	22,225	27	55,5	60,5	32	46	24,4	57	130	9,6	1	M10	19,3	5	5	0,10	0,25
● R-25	25	30	58	62,9	35	49	25,8	58	230	15	1,5	M10	20,8	5	5	0,12	0,27
○ R-1"	25,4	31	59	63,8	35	49	26,1	58	190	12	1,5	M10	21,2	5	5	0,13	0,29
○ R-1 1/8"	28,575	35	63,5	70,1	39	53	28,5	59	290	16	1,8	M10	23	5	5	0,18	0,35
● R-30	30	36	64,5	71,0	40	54	29,1	59	380	21	2	M10	23,6	5	5	0,19	0,35
○ R-1 1/4"	31,75	39	68,5	77,7	42	56	31,1	58	430	22	2,2	M10	24,8	5	5	0,25	0,42
○ R-1 3/8"	34,925	42	73	85,1	45	59	31,9	60,5	640	30	2,5	M10	26,4	5	5	0,31	0,47
● R-35	35	42	73	85,1	45	59	33,7	58	640	30	2,5	M10	26,4	5	5	0,32	0,48
○ R-1 1/2"	38,1	46	84,5	89,5	52	72	36,6	58	890	38	2,8	M16	31	8	21	0,76	0,84
○ R-40	40	48	86,5	91,2	55	75	37,7	59	1100	45	3	M16	32	8	21	0,84	0,88
○ R-1 3/4"	44,45	54	93	100,3	58	78	41,1	61	1400	51	3,5	M16	34,8	8	21	1,19	1,08
○ R-45	45	54	93	100,3	58	78	41,1	59	1400	51	3,5	M16	34,8	8	21	1,17	1,05
○ R-1 15/16"	49,2125	60	98,5	105,1	60	80	43,7	62	1900	63	4,5	M16	37,5	8	21	1,55	1,25
○ R-50	50	60	98,5	105,1	60	80	43,7	60	1900	63	4,5	M16	37,5	8	21	1,52	1,20
○ R-2"	50,8	61	101,5	111,8	60	80	45,2	60	1900	62	4,5	M16	38	8	21	1,72	1,28
● R-60	60	73	115,5	132,7	70	90	53,3	59	3300	90	5,3	M16	43,3	8	21	3,17	1,85
○ R-70	70	85	135,5	153,9	85	109	62	59	5600	130	6,4	M20	50,8	10	39	7,12	3,04
○ R-80	80	97	145,5	162,6	95	119	65,9	61	8700	180	7,5	M20	56,3	10	39	10,35	3,75

T = Transmittable torque when axial force is 0. } When the screw is tightened to T_t
 F_A = Transmittable axial force when torque is 0.
 F_R = Max transmittable radial force at continuous operation.
 Max allowed bending torque: 5% of transmittable torque T .

T_t = Recommended tightening torque for the screw.
 Further tightening does not increase the pressure.
 *) D_2 is valid before mounting.
 Dimensions subject to alterations without notice.

● From stock ○ on request

Tolerances

Shaft h8 (R-15 only h7).
Hub H7.

Type of torque

Transmittable torque, T , is for static load. If the load is alternating or pulsating torque, reduce the transmittable torque, T , with the following factors: (factor x T).

Alternating: 0,5 x T .
Pulsating: 0,6 x T .

Material

Type R: Euronorm 1.4418, stainless steel, X4CrNiMo16-5-1.
**)Screw: coated for a low and even friction in the threads.

Mounting advice

Make sure the screw thread is well lubricated before each mounting. We recommend the use of Molykote P-1900.

Special versions on request

ETP-EXPRESS R can be delivered in more corrosion resistant stainless steel and plated with Nickel.

ETP-TECHNO[®]

High precision and frequent mounting

ETP-TECHNO is a hydraulic connection with very high precision. It is especially designed for applications where fast frequent changes or adjustments, with high precision are needed. It can be mounted/dismantled 1000's of times.

ETP-TECHNO is very easy to mount with only one screw, and it also has extremely good concentricity.

ETP-TECHNO is the one to choose among the ETP hub-shaft connections when very high precision is needed.



Precision adjustment

In this machine for scraping aluminium bands, the spiral knives have to be set accurately in relation to each other and need to be changed quickly, when worn out. This and the good runout and compact design was the reason for the choice of ETP-TECHNO, for fastening the gears on the cutting wheel shaft.

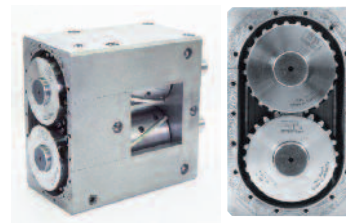

Frequent changes

In a test rig for vehicle gearboxes the output shaft is connected to a torque limiter with ETP-TECHNO to control the torque transmission. Many gearboxes are tested so the changes have to be done quickly. No backlash and radial access to the screw are also important.



Overload protection

ETP-TECHNO fastens the boring equipment in the front of this mobile boring machine. ETP-TECHNO do not rotate. If the boring equipment is subject to an overload it should not get damaged, ETP-TECHNO then slips instead, (part of a turn). The tolerance for the shaft and the tightening torque for the screw, have been calculated to limit the torque. The shaft surface and ETP-TECHNO are not damaged in this limited slippage. The boring equipment is repositioned, the screw is tightened easily and quickly.

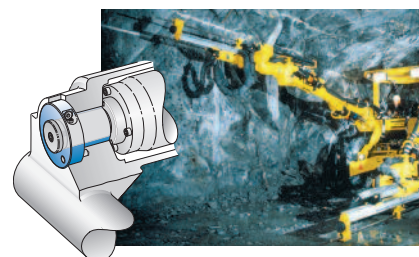

Good runout, moderate surface pressure

A gear of a special soft fibre material is fastened with ETP-TECHNO in special design for operating this printing machine. The moderate and even surface pressure from ETP-TECHNO makes sure that the expansion of the gear is limited. The hydraulic principle creates a good runout, small unbalance and thus a low noise level.

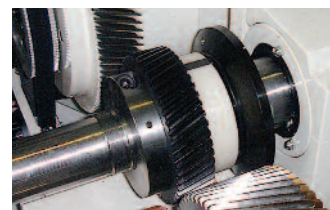

Radial tightening of one screw, good runout

When this gear, built into a drive line for a printing machine, is fixed there is no access in the axial direction. A bore has been machined through the black flange, through which it is possible to tighten the screw radially. The runout is important to get the precision in the gear drive and a minimum of backlash.



Low moment of inertia, quick changes

The coupling is used in a test bench for testing of gearboxes. ETP-TECHNO means that change of gearbox can be done quickly. The small built-in dimensions and the low weight for ETP-TECHNO, creates a minimum of moment of inertia. Also the good runout is important to minimise the unbalance.

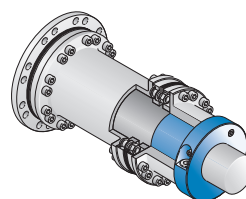

Good runout, frequent mounting

The speeds are often high and mounting is done frequently in this machine for measuring torque. The torque transmission is tested for example for motors and gearboxes. Fastening of the drive shaft is done with ETP-TECHNO of various sizes. The changes are done quickly and the fastening is very accurate.

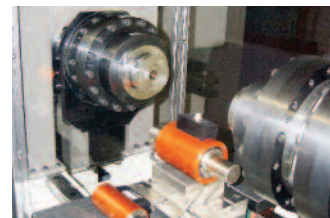

Good runout, quick tool change

A larger number of ETP-TECHNO in a special design, fasten the tooling in this punching machine. The good runout which is repeatable even after many changes is important. To minimize the downtime for tool change it is beneficial to have only one screw per connection. The radial access gives a compact design.





ETP-TECHNO is a hydraulic connection for high precision and frequent mounting. Available as standard for shafts 15 - 130 mm, also imperial. Runout $\leq 0,006$ mm.

Number of mountings 500 - 5 000 (size dependent). It has an extra seal consisting of a steel ball at the end of the piston, which is pressed against a spherical seating when mounted. ETP-TECHNO is often used as a base for special and customised solutions.

Construction

ETP-TECHNO is a hydraulic connection which consists of a double-walled hardened steel sleeve filled with a pressure medium, and a flange. The flange contains the pressure screw and piston with dual sealing function - an o-ring plus backup ring and a steel ball.

Operation

When the pressure screw is tightened, the double-walled sleeve expands uniformly against the shaft and the hub and creates a rigid joint. Dismantling of the joint is simply done by loosening the screw. ETP-TECHNO returns to its original measurements and can easily be dismantled.

BENEFITS & FEATURES

- Extremely fast mounting/dismantling with only ONE screw.
- Can be mounted/dismantled 1000's of times.
- Extremely good concentricity, ≤ 0.006 mm, also after several mountings.
- Dual sealing system.
- Radial tightening of the screw saves space along the shaft.
- Small built-in dimensions.
- Accurate positioning, no axial movement when mounting.

When the pressure screw is tightened to the recommended tightening torque, T_t , the steel ball seals against the spherical seating. ETP-TECHNO will create a uniform surface pressure against the shaft and hub.

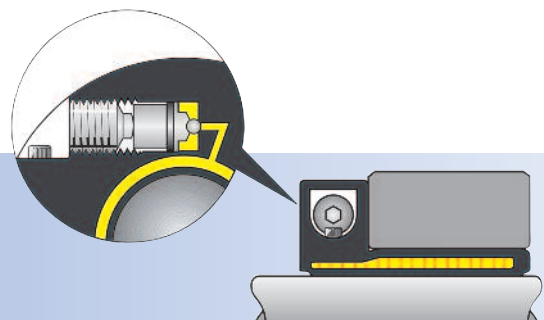

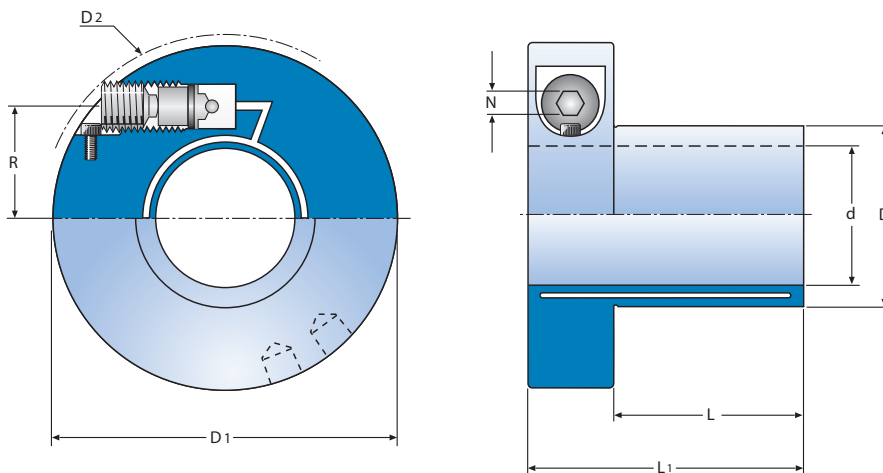
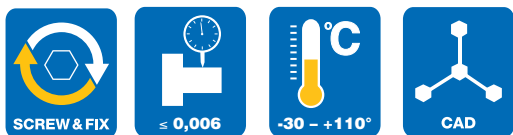

Notation: ETP-TECHNO XXX

Technical Specification ETP-TECHNO

ETP-TECHNO	Dimensions						Transmittable			Screws			Polar moment of inertia J kgm ² · 10 ⁻³	Weight kg	
	d mm	D mm	D ₁ mm	D ₂ * mm	L mm	L ₁ mm	torque T Nm	axial force F _A kN	radial force F _R kN	Dim.	R mm	N mm			Tt Nm
● 15	15	19	52	54	25	41	50	5	1	M12	16	6	10	0,09	0,25
● 20	20	25	59	61	30	46	145	12	2	M12	19	6	10	0,15	0,32
● 25	25	32	70	72	35	55	250	16	3	M14	24	6	16	0,38	0,58
○ 1"	25,4	32	70	72	35	55	250	16	3	M14	24	6	16	0,38	0,58
● 30	30	38	75	79	40	60	500	26	4	M14	25,5	6	16	0,54	0,69
○ 1 1/4"	31,75	41	79	83	42	62	510	25	4	M14	27,5	6	16	0,64	0,78
● 32	32	41	79	83	42	62	510	25	4	M14	27,5	6	16	0,64	0,78
● 35	35	44	84	90	45	65	740	34	5	M16	29,2	8	24	0,75	0,84
○ 1 1/2"	38,1	50	90	95	50	70	880	36	5	M16	32,5	8	24	1,1	1,08
● 40	40	52	91	98	55	75	1200	47	6	M16	32,7	8	24	1,3	1,18
● 45	45	56	96	105	58	78	1700	62	7	M16	34,7	8	24	1,5	1,24
● 50	50	65	110	117	60	85	2250	71	9	M20	40,5	10	40	2,3	1,64
○ 60	60	75	125	154	70	95	4400	119	12	M20	46,3	10	40	5	2,51
● 70	70	90	140	156	85	110	7000	158	13	M20	53	10	40	8,9	3,65
● 75	75	95	148	164	90	115	8600	183	14	M20	55,3	10	40	12	4,20
● 80	80	100	156	173	95	123	10900	218	15	M22	58,7	10	60	15	4,85
● 90	90	112	166	180	105	133	15500	277	17	2 x M22**	63,3	10	60	22	5,44
● 100	100	125	177	192	115	143	21000	335	19	2 x M22**	69,6	10	60	33	6,18
● 110	110	138	187	202	125	153	28000	410	21	2 x M22**	75,1	10	60	43	7,08
● 120	120	150	198	217	135	163	29000	393	23	2 x M22**	80,9	10	50	54	9,96
● 130	130	163	208	226	135	163	32000	393	25	2 x M22**	86,3	10	46	75	10,86

T= Transmittable torque when axial force is 0. } When the screw/screws is tightened to Tt.
 F_A=Transmittable axial force when torque is 0.
 F_R=Max transmittable radial force at continuous operation.
 Max allowed bending torque: 10% of transmittable torque T.

Tt= Recommended tightening torque for the screw/screws.
 Further tightening does not increase the pressure.
 *) D2 is valid before mounting.
 **) Pressure screws positioned in the same direction.
 Dimensions subject to alterations without notice.

● From stock ○ on request

Tolerances
 Shaft h8.
 Hub H7.

For further information see section Technical information/Design tips, page 52-55.

Type of torque

Transmittable torque, T, is for static load.
 If the load is alternating or pulsating torque, reduce the transmittable torque, T, with the following factors: (factor x T).
Alternating: 0,7 x T.
Pulsating: 0,8 x T.

ETP-POWER®

Fast mounting and
high radial loads

ETP-POWER is a hydraulic connection with the highest performance among the single screw ETP hub-shaft connections. With ETP-POWER all the positive benefits and features of hydraulic clamping, such as easy handling, compact design and precision, is combined with high radial load capacity due to the specific properties of the pressure medium.



Facilitates assembly of a machine

Manufacturing lines for laminated flooring contains many components, for example levers and timing pulleys, which need to be synchronised and free from backlash. When adjusting the timing belt drive, the pulley can be freely turned around and moved along the shaft and the belt tensioned.

ETP-POWER is used to fasten the large pulley as the tensioning forces applied by the belt leads to high radial loads. Also maintenance work time is saved as only one screw needs to be loosened/tightened.

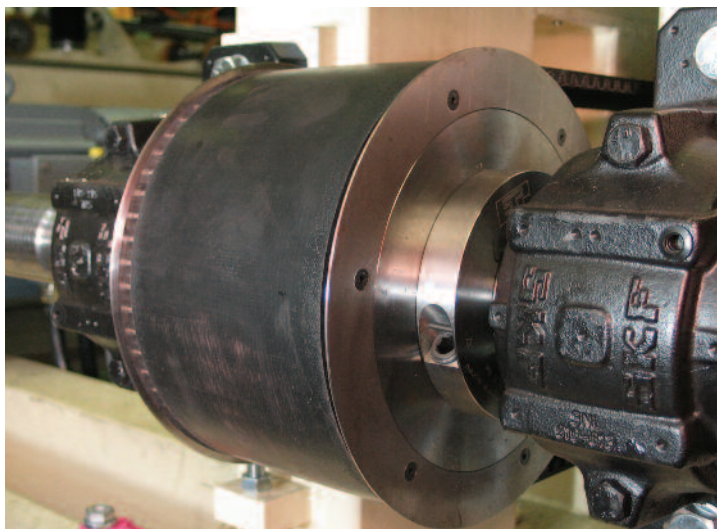

Good runout, no axial displacement

In this manufacturing line for aluminium radiators for cars, the rollers are fastened with ETP-POWER. In roller applications there are most often high radial loads applied making ETP-POWER the ideal choice. Also the positioning along the shaft is critical, this is easily adjusted and does not change when the screw is tightened. There are a lot of rollers in the line which are easily changed thanks to the features and benefits of ETP-POWER, when the production is changed.

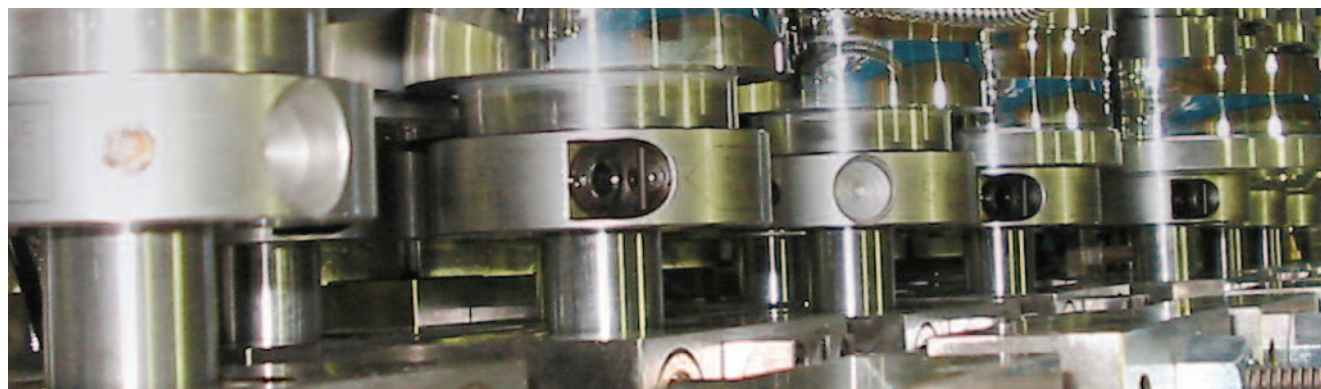
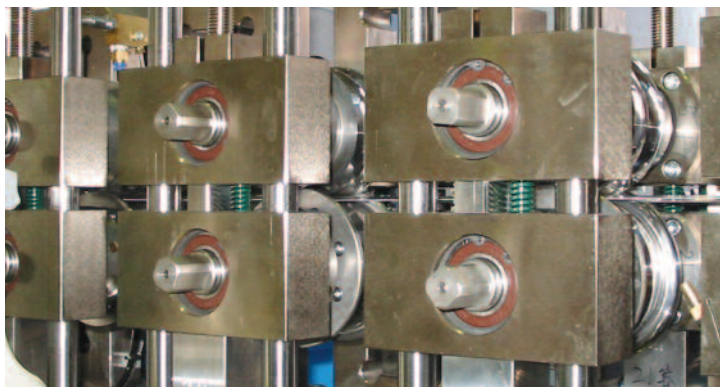



ETP-POWER is available as standard for shafts 15 – 40 mm. Runout $\leq 0,03$ mm. Number of mountings 200 - 500 (size dependent). ETP-POWER combines quick mounting with a high radial load capacity due to the specially developed pressure medium.

Construction

ETP-POWER is a hydraulic connection which consists of a double-walled hardened steel sleeve filled with a specially developed pressure medium and a flange. The flange part contains screw and piston with seals to maintain pressure. In the flange there are two pre-machined bores which can be used for mounting location pins, screws to the hub or similar.

Operation

When the pressure screw is tightened the double-walled sleeve expands uniformly against shaft and hub and creates a rigid joint. Dismantling is done by loosening the screw. ETP-POWER returns to its original dimensions and can easily be dismantled.

BENEFITS & FEATURES

- High radial load capacity.
- Fast mounting/dismantling with only ONE screw.
- Small built-in dimensions.
- Radial tightening of the screw saves space along the shaft.
- Accurate positioning, no axial movement when mounting.
- Good concentricity, also after several mountings.

When the pressure screw is tightened to the recommended tightening torque, the piston has reached the bottom of the bore. ETP-POWER has created a uniform surface pressure against the shaft and hub.

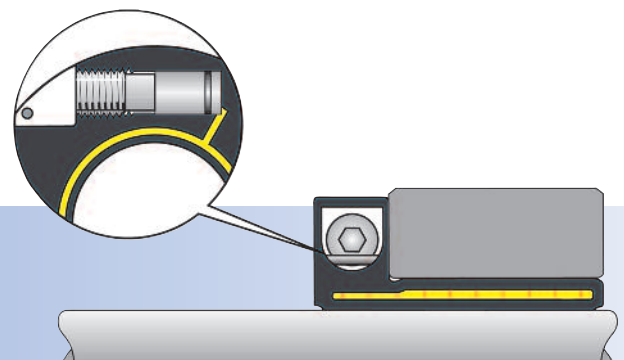

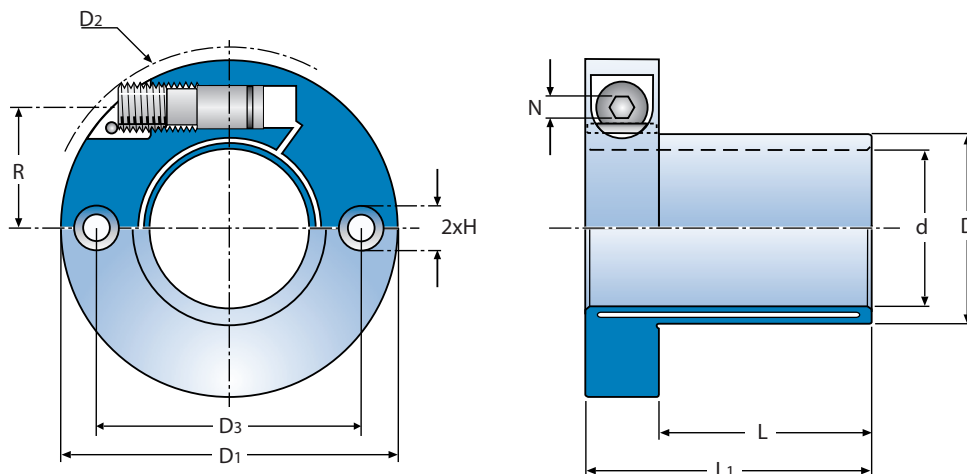

Notation: ETP-POWER XX

Technical Specification ETP-POWER

ETP-POWER®	Dimensions						Transmittable axial radial force			Pressure screw DIN 915, 12.9				Bores 2xH suitable for MC6S screws		Polar moment of inertia J kgm ² x10 ⁻³	Weight kg	
	d mm	D mm	D ₁ mm	D ₂ * mm	L mm	L ₁ mm	T Nm	F _A kN	F _R kN	Dim.	R mm	N mm	T _t Nm	D ₃ mm	Screw Dim.			
○	15	15	20	51	55	21	35	60	7	2	M10	17,1	5	8	36	M5	0,06	0,19
○	19	19	26	54	58	27	41	100	8	4	M10	18,2	5	8	40	M5	0,08	0,23
○	3/4"	19,05	26	54	58	27	41	100	8	4	M10	18,2	5	8	40	M5	0,08	0,23
○	20	20	27	55	59	28	42	130	11	4	M10	18,9	5	8	41	M5	0,09	0,24
○	22	22	29	58	62	29	43	210	15	4,8	M10	20,5	5	8	41	M5	0,11	0,27
○	24	24	32	64	70	33	47	230	15	5,6	M10	22,7	5	8	48	M6	0,17	0,34
○	25	25	33	67	72	34	48	300	20	6	M10	23,2	5	8	50	M6	0,21	0,38
○	1"	25,4	33	67	72	34	48	300	20	6	M10	23,2	5	8	50	M6	0,21	0,38
○	28	28	37	70	76	35	49	325	20	7,2	M10	24,9	5	8	53,5	M6	0,26	0,43
○	30	30	39	72	80	36	50	530	26	8	M10	26	5	8	55,5	M6	0,29	0,45
○	1 1/4"	31,75	43	85	92	38	58	550	26	8,8	M16	31	8	25	64,5	M8	0,73	0,82
○	32	32	43	85	92	38	58	550	26	8,8	M16	31	8	25	64,5	M8	0,73	0,82
○	35	35	46	88	94	40	60	900	40	10	M16	32,4	8	25	67	M8	0,85	0,88
○	38	38	50	90	96	44	64	1150	47	11,2	M16	33,1	8	25	70	M8	0,94	0,92
○	1 1/2"	38,1	50	90	96	44	64	1150	47	11,2	M16	33,1	8	25	70	M8	0,94	0,92
○	40	40	53	91	96	47	67	1200	47	12	M16	34,2	8	25	72	M8	1,0	1,0
○	1 3/4"	44,45	58	103	114	51	71	1600	70	14	M16	37,9	8	25	80,5	M8	1,3	1,3

T= Transmittable torque when axial force is 0. } When the screw is tightened to T_t
 F_A=Transmittable axial force when torque is 0.
 F_R=Max transmittable radial force at continuous operation.
 Max allowed bending torque: 10% of transmittable torque T.

T_t= Recommended tightening torque for the screw.
 Further tightening does not increase the pressure.
 *) D₂ is valid before mounting.
 Dimensions subject to alterations without notice.

● From stock ○ on request

TOLERANCES

Shaft k6-h7 for d = 19, 22, 24, 28, 32, 38 mm.
 Shaft h8 for all other dimensions d.

Hub H7.

For further information see section Technical information/Design tips, page 52-55.

Type of torque

Transmittable torque, T, is for static load.
 If the load is alternating or pulsating torque, reduce the transmittable torque, T, with the following factors: (factor x T).
 Alternating: 0,5 x T.
 Pulsating: 0,6 x T.

ETP-CLASSIC®

The original - competitive connection for normal needs



ETP-CLASSIC is used in a large variety of applications, for mounting timing belt pulleys, cam curves and arms etc. Positioning along and around the shaft is easy and fast with high precision. Service and maintenance are also quick because of the easy dismantling.

ETP-CLASSIC is recommended for all normal needs. ETP-CLASSIC is also available in stainless, type R, suitable for the food and medical industries.

No backlash

In this robot used for loading machine tools, sometimes the arms need to be changed quickly. The new arms need to be positioned accurately and without backlash. For this ETP-CLASSIC was the best choice.

Setting, adjustment

Packaging machines have a lot of moving parts, such as gears, cams and levers, which during assembly has to be accurately positioned in relation to each other, both axially and radially. This is made easily with the use of ETP-CLASSIC.

Easy positioning

In this label printing machine used within the beverage industry an exact adjustment is needed, to get the labels on at the right time and position. A number of ETP-CLASSIC is used for the positioning of timing pulleys and other components. In all places where the connection is visible, stainless steel is needed, due to wash down requirements. ETP-CLASSIC R was found to be ideal for this.





ETP-CLASSIC is available as standard for shafts 15-100 mm, also imperial and a short version, (type S). Also available in stainless steel (type R).
Runout: 0,03 – 0,06 mm. Number of mountings: 100 (type R: 50). The small number of clamping screws with low tightening torque, makes the mounting/dismantling procedure fast and easy.

Construction

ETP-CLASSIC is a hydraulic connection which consists of a double-walled hardened steel sleeve, filled with a specially developed pressure medium, sealing ring, piston, pressure flange and cap head clamping screws.

ETP-CLASSIC type R is made of stainless steel and has hex head stainless steel clamping screws. This in order to facilitate easy cleaning, essential within food processing.

Operation

When tightening the screws, the sleeve expands uniformly against hub and shaft and creates a rigid joint. When loosening the screws, the sleeve returns to its original measurements and can easily be dismantled.

ETP-CLASSIC type R has a few more clamping screws, as the tightening torque is lower for stainless steel screws.

BENEFITS & FEATURES

- Small built-in dimensions.
- Mounting and dismantling is fast.
- Fine adjustment of the hub can be made during mounting.
- Low tightening torque and a small number of screws makes the mounting easy.
- Good concentricity, also after several mountings.
- Hex head screws available as accessories.

When the screws have been tightened, ETP-CLASSIC creates an even surface pressure against the hub and shaft along virtually the entire length.

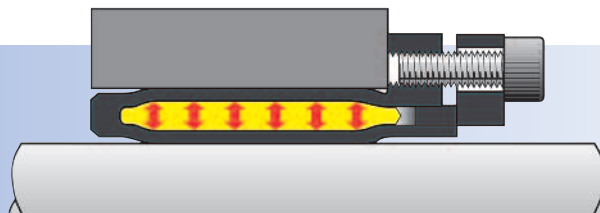



0,03 – 0,06



-30 – +85°



CAD

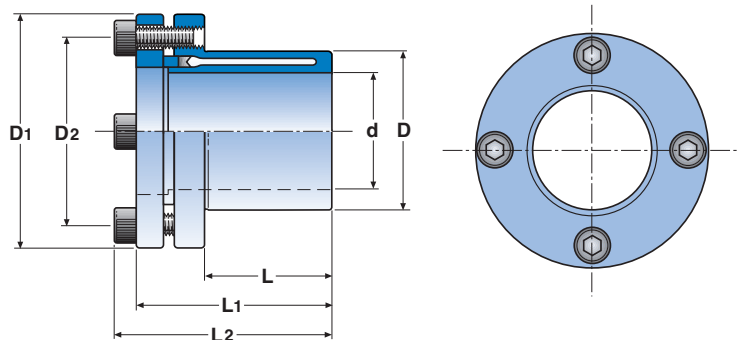

Notation: ETP-CLASSIC XXX

Technical Specification ETP-CLASSIC

ETP-CLASSIC	Dimensions							Transmittable torque axial force radial force			Screws DIN 912, 12.9			Polar moment of inertia J kgm ² · 10 ⁻³	Weight kg	
	d mm	D mm	D ₁ mm	D ₂ mm	L mm	L ₁ * mm	L ₂ * mm	T Nm	F _A kN	F _R kN	No.	Dim.	T _t Nm			
●	15	15	23	38	28,5	17	30	35	55	7,3	2,5	3	M5	6	0,019	0,10
●	19	19	28	45	35	21	37	42	100	10,6	5,8	3	M5	8	0,045	0,17
●	20	20	28	45	35	22	37	42	125	12,5	6,6	3	M5	8	0,043	0,16
●	22	22	32	49	40	22	37	42	135	12,3	8,2	4	M5	8	0,063	0,20
●	24	24	34	49	40	25	40	45	200	16,7	9,8	4	M5	8	0,066	0,20
●	25	25	34	49	40	27	43	48	250	20,0	10,6	4	M5	8	0,067	0,20
●	28	28	39	55	46	29	45	50	300	21,4	13,1	4	M5	8	0,112	0,27
●	30	30	41	57	47,5	32	47	52	420	28,0	14,7	4	M5	8	0,133	0,30
●	32	32	43	60	50,5	34	52	57	420	26,3	16,3	4	M5	8	0,180	0,35
●	35	35	47	63	53,5	37	55	60	650	37,1	18,8	6	M5	8	0,230	0,41
●	38	38	50	65	56	41	59	64	750	39,5	21,2	6	M5	8	0,277	0,44
●	40	40	53	70	60,5	43	63	68	940	47,0	22,8	6	M5	8	0,408	0,57
●	42	42	55	70	60,5	45	65	70	940	44,8	24,4	6	M5	8	0,414	0,56
●	45	45	59	77	66,5	49	69	75	1290	57,3	26,9	6	M6	13	0,636	0,73
●	48	48	62	80	69,5	52	73	79	1570	65,4	29,3	6	M6	13	0,761	0,80
●	50	50	65	83	72,5	53	76	82	1900	76,0	30,9	6	M6	13	0,943	0,91
●	55	55	71	88	78	58	82	88	2500	90,9	35,0	8	M6	13	1,301	1,09
●	60	60	77	95	84,5	64	90	96	3400	113	39,1	8	M6	13	1,959	1,40
●	65	65	84	102	91	68	96	102	3500	108	43,1	8	M6	13	2,780	1,72
●	70	70	90	113	99	72	99	107	5200	149	47,2	6	M8	32	4,035	2,09
●	75	75	95	118	104	85	114	122	6300	168	51,3	6	M8	32	5,500	2,51
●	80	80	100	123	109	90	120	128	8800	220	55,0	6	M8	32	8,100	2,68
●	85	85	106	129	115	95	125	133	8800	207	58,0	6	M8	32	9,500	3,09
●	90	90	112	135	121	100	133	141	11000	244	60,0	8	M8	32	12,200	3,52
●	95	95	120	143	129	105	139	147	12800	269	61,5	8	M8	32	17,100	4,46
●	100	100	125	148	134	110	145	153	15500	310	62,0	8	M8	32	19,950	4,87

T= Transmittable torque when axial force is 0. } When the screw is tightened to T_t.
 F_A=Transmittable axial force when torque is 0. }
 F_R=Max transmittable radial force at continuous operation.
 Max allowed bending torque: 15% of transmittable torque T.

T_t= Recommended tightening torque for the screws.
 *) The dimensions are valid before mounting.

Dimensions subject to alterations without notice.

● From stock ○ on request

TOLERANCES

Shaft h8 – k6 (size 15 only h7)

When using k6 shaft – transmittable torque will increase by 20%.

Can also be used with h9 shaft – Transmittable torque will be reduced by 25%.

Hub H7.

Type of torque

Transmittable torque, T, is for static load.

If the load is alternating or pulsating torque, reduce the transmittable torque, T, with the following factors: (factor x T).

Alternating: 0,6 x T for sizes 15 – 30 mm.

0,5 x T for sizes 32 – 100 mm.

Pulsating: 0,7 x T for sizes 15 – 30 mm.

0,6 x T for sizes 32 – 100 mm.

Tightening torque

By increasing the tightening torque of the screw sizes according to the table, the transmittable torque can be increased by 25%.

Note: Only to be used when operating temperature ≤ mounting temperature.

Max. tightening torque (screw quality 12.9)

M5	M6	M8
10 Nm	17 Nm	40 Nm

Technical Specification ETP-CLASSIC in inch

ETP-CLASSIC®	Dimensions						Transmittable torque or axial force		Screws DIN 912, 12.9		
	d tum	D mm	D ₁ mm	L mm	L ₁ mm	L ₂ mm	T Nm	F _A kN	No.	Dim.	Tt Nm
3/4"	3/4"	28	45	21	35	40	88	9,3	3	M5	8
7/8"	7/8"	32	49	22	37	42	135	12,1	4	M5	8
15/16"	15/16"	34	49	25	39	44	175	14,7	4	M5	8
1"	1"	35	51	27	41	46	195	16,2	4	M5	8
1 1/8"	1 1/8"	39	55	29	43	48	280	19,5	4	M5	8
1 3/16"	1 3/16"	41	57	32	47	52	340	22,5	4	M5	8
1 1/4"	1 1/4"	43	60	34	50	55	410	26,1	4	M6	13
1 3/8"	1 3/8"	47	63	37	53	58	540	31,1	6	M5	8
1 7/16"	1 7/16"	50	65	37	54	59	580	31,8	6	M5	8
1 1/2"	1 1/2"	52	68	41	57	62	700	36,7	6	M5	8
1 5/8"	1 5/8"	55	70	44	63	68	850	41,2	6	M5	8
1 3/4"	1 3/4"	59	77	49	67	73	1180	53,0	6	M6	13
1 15/16"	1 15/16"	65	83	52	74	80	1450	58,9	6	M6	13
2"	2"	68	88	53	74	80	1620	64,3	6	M6	13
2 7/16"	2 7/16"	81	99	60	85	91	2800	90,5	8	M6	13
2 1/2"	2 1/2"	84	107	62	86	94	3100	97,6	6	M8	32
2 15/16"	2 15/16"	95	118	85	108	116	5300	153,0	6	M8	32
3"	3"	98	121	74	101	109	5300	139,1	6	M8	32
4"	4"	130	155	97	128	136	12500	264,0	8	M8	32

ETP-CLASSIC is also available in a large assortment of inch sizes. The main dimensions are given in the table, for more information please refer to technical data for ETP-CLASSIC.

TOLERANCES

ETP-CLASSIC	Shaft tolerance
3/4"	0 to -0,0015"
7/8" – 1 1/2"	0 to -0,0020"
1 5/8" – 2 15/16"	0 to -0,0030"
3"	0 to -0,0040"
4"	0 to -0,0030"

ETP-CLASSIC	Hub tolerance
3/4" - 1 15/16"	0 to +0,0010"
2" – 2 7/16"	0 to +0,0012"
2 1/2" – 4"	0 to +0,0014"

Notation ETP-CLASSIC S-XX

Technical Specification ETP-CLASSIC type S

ETP-CLASSIC®	Dimensions						Transmittable torque or axial force		Screws DIN 912, 12.9			Weight kg
	d mm	D mm	D ₁ mm	L mm	L ₁ mm	L ₂ mm	T Nm	F _A kN	No.	Dim.	Tt Nm	
S-19	19	28	45	13	26	31	53	5	3	M5	8	0,15
S-20	20	28	45	15	28	33	75	6	3	M5	8	0,14
S-25	25	34	49	15	29	34	120	10	4	M5	8	0,17
S-30	30	41	57	20	34	39	210	14	4	M5	8	0,24
S-35	35	47	63	22	38	43	330	19	6	M5	8	0,32
S-40	40	53	70	25	42	47	500	26	6	M5	8	0,46
S-45	45	59	77	28	45	51	700	31	6	M6	13	0,57
S-50	50	65	83	26	45	51	1000	40	6	M6	13	0,72

ETP-CLASSIC is also available in a shorter version, type S, which is especially suitable for small hubs. The main dimensions are given in the table, for more information please refer to technical data for ETP-CLASSIC.

TOLERANCES

Shaft: h9 (for size 19: k6-h8).

Hub: H7.



Notation: ETP-CLASSIC R-XX

Technical Specification ETP-CLASSIC R

ETP-CLASSIC®	Dimensions							Transmittable torque axial force radial force			Screws**) DIN 933, A4			Polar moment of inertia J kgm ² · 10 ⁻³	Weight kg
	d mm	D mm	D ₁ mm	D ₂ mm	L mm	L ₁ * mm	L ₂ * mm	T Nm	F _A kN	F _R kN	Ant.	Dim.	Tt Nm		
R-15	15	23	38	28,5	17	30	34	45	6,0	2,5	4	M5	4,5	0,019	0,10
R-20	20	28	45	35	22	37	41	100	10,0	6,6	5	M5	4,5	0,044	0,16
R-25	25	34	49	40	27	43	47	210	16,8	10,6	7	M5	4,5	0,070	0,21
R-30	30	41	57	47,5	32	47	51	350	23,3	14,7	7	M5	4,5	0,137	0,30
R-35	35	47	63	53,5	37	55	59	500	28,5	18,8	9	M5	4,5	0,234	0,41
R-40	40	53	70	60,5	43	63	67	750	37,5	22,8	9	M5	4,5	0,414	0,58
R-45	45	59	77	66,5	49	69	73	1100	48,8	26,9	9	M6	7,8	0,647	0,74
R-50	50	65	83	72,5	53	76	80	1550	62,0	30,9	9	M6	7,8	0,957	0,92

T= Transmittable torque when axial force is 0. } When the screw is tightened to Tt.
 F_A=Transmittable axial force when torque is 0. }
 F_R=Max transmittable radial force at continuous operation.
 Max allowed bending torque: 15% of transmittable torque T.

Tt= Recommended tightening torque for the screws.
 *) The dimensions are valid before mounting.

Dimensions subject to alterations without notice.

● From stock ○ on request

TOLERANCES

Shaft h8 (size R-15 only h7)

Hub H7.

Material

Euronorm 1.4542, stainless steel,
 X5CrNiCuNb16-4.

**Screws: coated for a low and even friction in the threads.

Mounting advice

Make sure the screw thread is well lubricated before each mounting.

We recommend the use of Molykote P-1900.

ETP-MINI®

Quick compact fastening of small components

ETP-MINI is a mechanical connection which is the best choice for mounting small components quick and easy. Far superior to keyways or setscrews as it gives an adjustable, backlash free joint.

ETP-MINI is also available in stainless, type R, suitable for the food and medical industries.



ETP-MINI is available as standard for shafts 6 -14 mm, also imperial. Runout $\leq 0,02$ mm. Number of mountings 100 (type R: 50). ETP-MINI is one of the most compact mechanical hub-shaft connections on the market, allowing you to optimise your design.

Construction

ETP-MINI is a mechanical connection which consists of two, partly slotted, conical steel sleeves (type R stainless) and cap head clamping screws (type R stainless).

Operation

By tightening the screws, the inner sleeve is pressed against the shaft and the outer sleeve against the hub, thus forming a rigid joint. When dismantling one, or if necessary, two of the screws are moved to the threaded dismantling holes in the flange. By tightening, the sleeves will separate and the joint will easily loosen. ETP-MINI type R has one screw more than ETP-MINI in order to transmit the same torque (lower tightening torque for stainless screws).

BENEFITS & FEATURES

- Quick and easy mounting.
- Good runout.
- Allows wide tolerances.
- Available in stainless steel (type R).
- For ETP-MINI R – stainless hex head screws available as accessories.

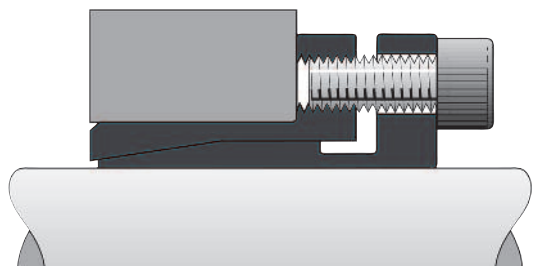

The inner sleeve of ETP-MINI has a light recess close to the flange in order to create a more uniform surface pressure to the shaft.



ETP-MINI R, suitable for the food industry.

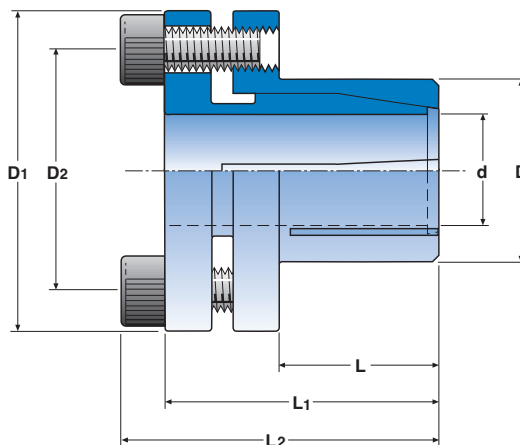

Notation: ETP-MINI XX

Technical Specification ETP-MINI

ETP-MINI	Dimensions							Transmittable torque or axial force		Screws DIN 912, 12.9			Polar moment of inertia J kgm ² · 10 ⁻⁶	Weight kg
	d mm	D mm	D ₁ mm	D ₂ mm	L mm	L ₁ * mm	L ₂ * mm	T Nm	F _A kN	No.	Dim.	T _t Nm		
6	6	14	25	18	10	19	22	7	2,5	2	M3	2	2,1	0,03
1/4"	6,35	14	25	18	10	19	22	8	2,5	2	M3	2	2,1	0,03
8	8	15	27	20	12	21,5	25,5	20	5	2	M4	4	3,3	0,04
9	9	16	28	21	14	24	28	28	6,5	2	M4	4	4,4	0,05
3/8"	9,525	16	28	21	14	24	28	30	6,5	2	M4	4	4,4	0,05
10	10	16	28	21	14	24	28	34	6,5	2	M4	4	4,3	0,05
11	11	18	30	23	14	25,5	29,5	36	6,5	2	M4	4	6,2	0,06
12	12	18	30	23	14	25,5	29,5	40	6,5	2	M4	4	6,1	0,06
1/2"	12,7	18	30	23	14	25,5	29,5	42	6,5	2	M4	4	6,0	0,06
14	14	22	35	27	15	27,5	31,5	66	9,5	3	M4	4	13,2	0,08

T= Transmittable torque when axial force is 0. } When the screws are tightened to T_t.
 F_A=Transmittable axial force when torque is 0. }
 T_t= Recommended tightening torque for the screws.

*) The dimensions are valid before mounting.

Dimensions subject to alternations without notice.



Notation: ETP-MINI R-XX

Technical Specification ETP-MINI type R

ETP-MINI®	Dimensions							Transmittable torque or axial force		Screws **) DIN 912, A4			Polar moment of inertia J kgm ² · 10 ⁻⁶	Weight kg
	d mm	D mm	D ₁ mm	D ₂ mm	L mm	L ₁ * mm	L ₂ * mm	T Nm	F _A kN	No.	Dim.	T _t Nm		
R-6	6	14	25	18	10	19	22	5	1,7	3	M3	1,2	2,1	0,03
R-8	8	15	27	20	12	21,5	25,5	17	4,4	3	M4	2,7	3,3	0,04
R-9	9	16	28	21	14	24	28	20	4,4	3	M4	2,7	4,4	0,05
R-10	10	16	28	21	14	24	28	23	4,4	3	M4	2,7	4,3	0,05
R-11	11	18	30	23	14	25,5	29,5	25	4,4	3	M4	2,7	6,2	0,06
R-12	12	18	30	23	14	25,5	29,5	27	4,4	3	M4	2,7	6,1	0,06
R-1 1/2"	12,7	18	30	23	14	25,5	29,5	28	4,4	3	M4	2,7	6,1	0,06
R-14	14	22	35	27	15	27,5	31,5	48	6,5	4	M4	2,7	13,2	0,08

T= Transmittable torque when axial force is 0. } When the screws are tightened to T_t.
 F_A=Transmittable axial force when torque is 0. }
 T_t= Recommended tightening torque for the screws.

*) The dimensions are valid before mounting.

Dimensions subject to alternations without notice.

● From stock ○ on request

TOLERANCES

Shaft: k6-h10.
 Hub: H8.

MATERIAL FOR TYPE R

Euronorm 1.4305, stainless steel, X10CrNiS18-9.
 **)Screws: surface coated for a low and even friction in the threads.

MOUNTING ADVICE

Make sure the screw threads for type R are well lubricated before each mounting. We recommend the use of Molykote P-1900.

ETP-HYLOC®

For heavy loads and quick mounting

ETP-HYLOC is a hydro-mechanical hub-shaft connection which, due to its robust design, is ideally suited to work in difficult environments and heavy operations like steel rolling mills, process industries etc. An interesting application, among many, has been fastening of feeding or forming rolls to shafts. ETP-HYLOC is fast to mount, has good concentricity and can take high torque and radial loads. Mounting and dismantling is easily carried out with a hydraulic pump.



Good runout, easy to position

In this straightening line for steel, the forming rollers are fastened with ETP-HYLOC. The position of the rollers relatively to each other along the shafts are exactly adjusted, it will not change during pressurising. The radial runout is minimised and the change of rollers facilitated. High radial forces can be transmitted with ETP-HYLOC, as the connection is solid all through.



Good runout, simple to adjust

ETP-HYLOC, due to its robust design, is suited for difficult environments and heavy operations. Here the feed rollers are fastened in a steel mill. Adjustment of the rollers is easy to do and with high precision. When in operation the good runout is important. When the rollers need to be changed the quick dismantling is valuable to decrease down time.



Good runout, thin hub

Fastening and centering of a turbine runner puts high requirements on the connection. Often a relatively soft material is used in the hub, which should be subject to a limited tension. The moderate and even surface pressure from ETP-HYLOC works well also with thin walled hubs. The high speeds require good runout. Mounting and adjusting is made easy and fast due to the easy pressure setting.



High torque, no backlash

The gear for operating a machine for production of pet food is fastened with ETP-HYLOC. Important at the selection was the accurate adjustment to avoid backlash, the possibility to take up high peak loads at emergency stops, as well as the easy and quick mounting.



High radial force, quick changes

Centering and fastening of the feed rollers in a processing line for steel working. ETP-HYLOC centres the rollers, take up and transfers the high and irregular radial forces to the shaft. Adjustments to change worn out rollers and change to other profiles are done with a minimum of downtime, with the help of only a hydraulic handpump.

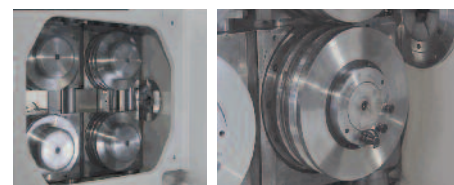

Precision fastening, quick adjustment

Fastening of the measuring shaft and the part which will be subject to a torque, in this torque test rig in the automobile industry, are both done with ETP-HYLOC. Precision, no backlash, limited surface pressure that does not damage the surfaces and quick change of parts to be tested are important factors.



High axial forces, simple adjustment

In this test equipment, volcano rock samples are subject to compression tests under high temperature. ETP-HYLOC fasten the top reaction plate to the vertical shafts and take up the high axial forces. When adjusting for a new sample, the reaction plate is raised and lowered again, the connections can be easily loosened and set again.



Accurate positioning, dynamic loads

Four chop and trimming shears in this machine, which belongs to a processing line for steel, must be accurately synchronised. On each wheel there are a number of knives, which trim front and back end coils which passes through. ETP-HYLOC centres and fastens the wheels. The knives are synchronised along and around the shafts and maintain their accurate positions during pressurising. The uneven dynamic loads in the radial direction are transferred through ETP-HYLOC.

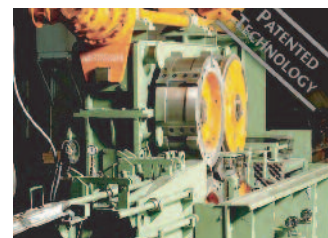

Heavy loads and quick mounting



ETP-HYLOC is available as standard for shafts 50 - 220 mm. Runout $\leq 0,02$ mm. Number of mountings: Max. 2 000. Customized models for shaft > 220 mm can also be offered on request.

For extreme high torque applications the contact surfaces of ETP-HYLOC (sizes ≥ 100 mm) can be plated with ETP-HFC, High Friction Coating, which doubles the torque capacity.

Construction

ETP-HYLOC is a hydro-mechanical joint, which consists of a double-walled steel sleeve which encloses a conical moveable piston. Mounting and dismantling is carried out with a hydraulic pump. In the flange there are three threaded connections ("ON", "P" and "OFF") in the radial direction and the same in the axial. This makes it possible to choose radial or axial connection of the pump hoses, depending on the build-in situation.

Operation

When the piston is moved, by the hydraulic pressure from the pump, the double-walled sleeve expands uniformly against shaft and hub to form a rigid joint. When dismantling, the piston is moved in the opposite direction and the joint will loosen. A small amount of oil will be taken via spiral tracks in the piston between the surfaces (pressure applied through the "P" connection), in this way making it easier for the piston to move. Normal working pressure is 1 000 bar.

BENEFITS & FEATURES

- High transmittable torque capacity - can be varied by changing the mounting pressure.
- Fast mounting/dismantling in tight spaces.
- High radial load capacity.
- Radial and axial connection is possible.
- Fine adjustments of the hub can be made when mounting.
- Good concentricity, also after several mountings.
- With ETP-HFC coating – double torque capacity.

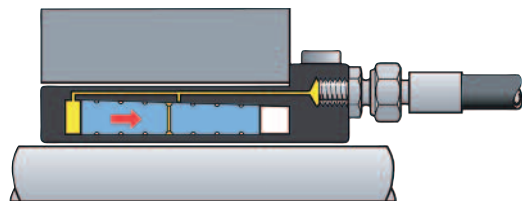

Mounting: apply pressure in the "ON" and "P" (not shown) connections. When mounted no hydraulic pressure remains. The small conical angle prevents the piston from releasing.

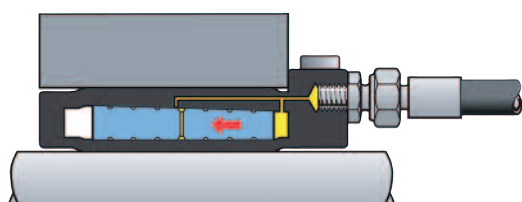

Dismantling: apply pressure in the "OFF" and "P" (not shown) connections. ETP-HYLOC returns to its original measurements and the joint is loose.

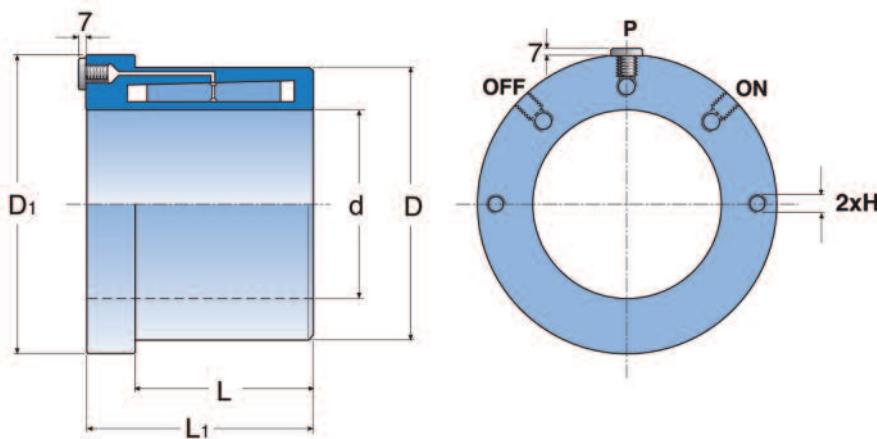

Notation: ETP-HYLOC XXX

Technical Specification ETP-HYLOC

ETP-HYLOC	Dimensions					Transmittable torque or axial force at 1000 bar					H	Polar moment of inertia J kgm ² · 10 ⁻³	Weight kg	
	d mm	D mm	D ₁ mm	L mm	L ₁ mm	Shaft h7		Shaft h8		Min hub DH mm				
						T kNm	F _A kN	T kNm	F _A kN	Yieldpoint N/mm ² >300				>400
50	50	77	101	56	82	2,6	70	2,4	70	110	105	M8	3,2	2,4
60	60	89	113	64	90	4,6	130	4,3	130	140	125	M8	5,4	3,1
70	70	102	122	74	100	7,9	210	7,4	200	170	145	M8	8,7	4,1
80	80	115	135	84	110	12,1	290	11,5	280	200	160	M8	14	5,4
90	90	128	148	94	120	17,1	380	16,2	360	235	180	M12	23	7,0
100	100	140	160	104	130	24,2	485	23,1	460	270	200	M12	34	8,6
110	110	154	173	114	140	32,9	595	31,5	570	295	220	M12	51	11
120	120	168	186	124	150	43,2	720	41,6	690	320	240	M12	76	14
130	130	182	200	134	160	53,8	825	51,4	790	350	260	M16	110	17
140	140	196	213	144	170	68,9	985	66,2	945	375	280	M16	150	21
150	150	210	227	154	180	85,4	1135	82,3	1095	400	300	M16	210	25
160	160	224	240	164	190	104	1305	100	1260	425	320	M16	290	30
180	180	252	267	184	210	150	1675	146	1625	480	360	M16	500	42
200	200	280	293	204	230	206	2060	200	2000	535	400	M16	830	56
220	220	308	320	224	250	273	2485	266	2415	585	435	M16	1300	73

ETP-HYLOC	600 bar				800 bar				1200 bar			
	Shaft h7		Min. hub DH		Shaft h7		Min. hub DH		Shaft h7		Min. hub DH	
	T	T	Yieldpoint	Yieldpoint	T	T	Yieldpoint	Yieldpoint	T	T	Yieldpoint	Yieldpoint
	kNm	kNm	N/mm ² >200	>300	>400	kNm	kNm	N/mm ² >300	>400	kNm	kNm	N/mm ² >400
50	0,8	0,8	90	90	90	1,6	1,4	95	90	3,3	3,1	130
60	1,1	1,1	115	105	95	3,3	3	120	110	5,9	5,6	155
70	2,4	2,4	135	120	110	5,8	5,3	140	125	9,9	9,5	170
80	5,6	5,3	155	140	130	9	8,4	165	140	15,3	14,6	190
90	8,3	7,4	180	160	145	12,7	11,8	185	160	21,6	20,6	215
100	12,1	11	200	170	160	18,2	17,1	210	180	30,3	29,2	235
110	16,8	15,4	220	195	180	24,8	23,5	235	195	41	39,6	260
120	22,3	20,6	240	215	195	32,7	31,1	255	215	53,7	52	280
130	27,2	24,9	260	230	210	40,5	38,1	275	230	67	64,7	305
140	35,6	32,9	285	250	225	52,3	49,6	295	250	85,6	82,9	325
150	44,5	41,4	300	265	240	65	61,9	315	265	105	102	350
160	54,8	51,2	320	285	260	79,5	76	335	285	129	125	370
180	80	75	360	320	290	115	110	375	320	186	181	415
200	109	103	400	355	320	157	151	420	355	254	248	465
220	144	137	440	390	355	209	201	460	390	338	330	510

T = transmittable torque when axial force is 0.
 F_A = transmittable axial force when torque is 0.
 DH = Outer diameter for hub material in steel.

H: Threads for easy handling.
 Dimension subject to alterations without notice.

TOLERANCES

Shaft h7 or h8
 Hub H7

MOUNTING – ADVICE

The contact surfaces L and L₁ must be completely covered by the shaft and hub. The oil for the pump should be a transmission oil type 80 W. For other hub materials, for example aluminium, contact us.

MOUNTING PRESSURE

The mounting pressure is normally 1000 bar. Max mounting pressure 1200 bar. Dismantling requires approx. 200 bar higher pressure than for mounting.

ETP-HYLOC can be designed to suit special applications on request, and also larger sizes are available.

For further information see section Technical information/Design tips, page 52-55.

Transmittable torque at different mounting pressures.

The torque for sizes ≥100 can be increased by using ETP-HFC

● From stock ○ on request

ETP-OCTOPUS[®]

For fast, frequent and accurate linear positioning

The hydraulic connection ETP-OCTOPUS is suitable when repositioning of machine parts are going to be done frequently, fast and with high precision along the shaft, for example in machine tools for qualified machining or forming of steel. With the use of an external hydraulic pressure source one or several connections can be clamped or loosened simultaneously.

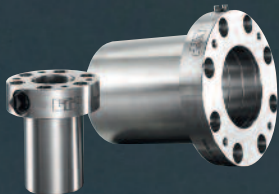

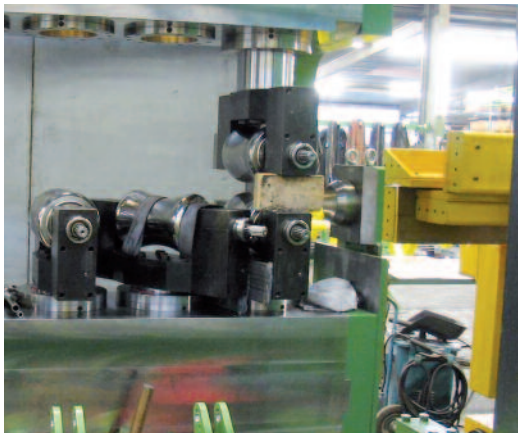

Exact positioning – low downtime

In this cold forming machine for steel tubes ETP-OCTOPUS 180 is used to fix the hydraulic pistons in required positions. The positions depends on the size of the tubes. At the end of the piston you find the forming tools. This allows a stepless positioning of each forming roller. The set up and downtime will be minimized.

Fast changes – high flexibility

In a tablet compaction test equipment the compression tooling is often cam driven, so a change of tablet type requires a manual re-setting of the machine. In this machine the tooling is locked with hydraulics, using ETP-OCTOPUS, enabling a higher flexibility and faster changes.

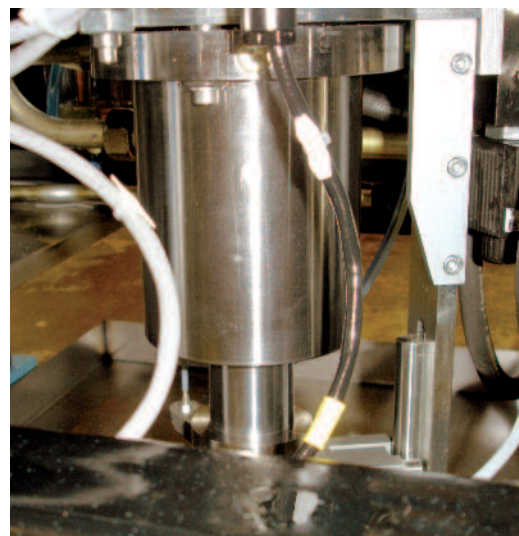

Frequent repositioning

ETP-OCTOPUS is suitable when repositioning of machine parts are going to be done frequently, fast and with high precision, for example in machine tools for qualified machining or forming of steel. With hydraulic pressure one or several ETP-OCTOPUS are clamped or loosened simultaneously.

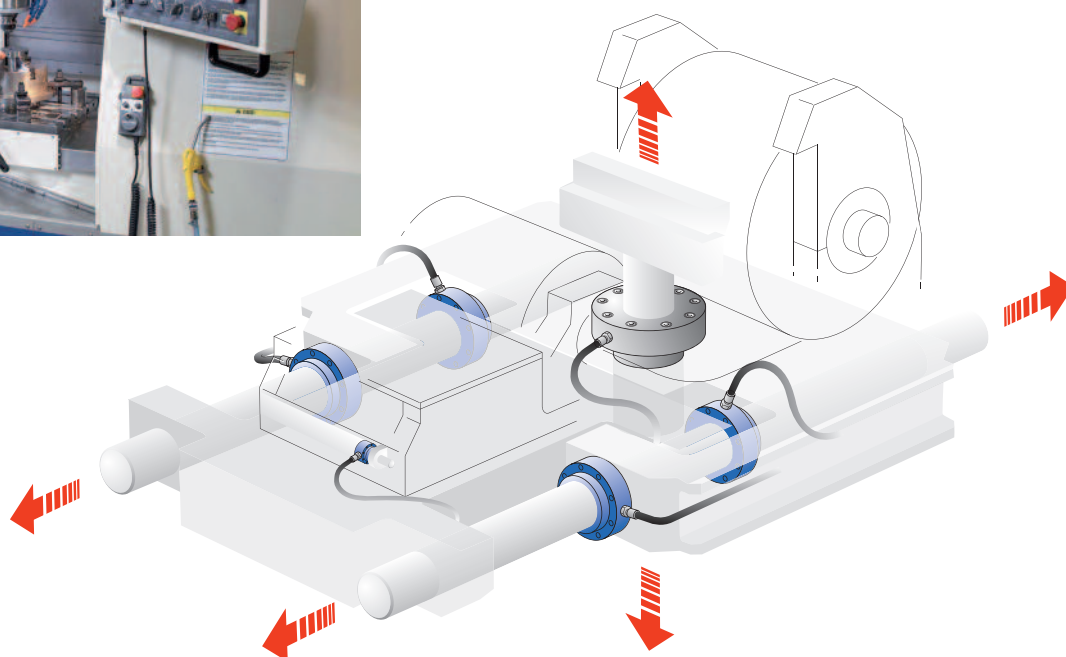

Accurate linear positioning



ETP-OCTOPUS is available as standard for shafts 30-100 mm. Number of mountings 100 000 – 500 000. (pressure dependent). ETP-OCTOPUS is easy to build in, as no hub is required, and allows for fast, frequent and accurate positioning. Customized designs are also offered on request.

Construction

ETP-OCTOPUS is a hydraulic connection which consists of a double-walled hardened steel sleeve with a flange. In the flange there are bores for mounting of a hub and a scraper with a screw joint, threaded connection for hydraulic oil and an air relief screw. The inner diameter has spiral tracks in order to get an even friction and a defined locking force to the shaft.

Operation

The assembly of the hub is done with the screw joint. When hydraulically pressurized the inner sleeve expands uniformly against the shaft and creates a rigid joint. The sleeve does not expand to the outside.

When the pressure is released the sleeve returns to its original size and can then easily be moved along the shaft to its new position and be re-pressurized.

BENEFITS & FEATURES

- Easy to build in.
- Fast and accurate positioning.
- Allows up to 500 000 pressure settings
- High torsional stiffness.
- Both axial force and torque can be transmitted.

No hub is required for a design with ETP-OCTOPUS as the sleeve is thick enough to withstand the hydraulic pressure.

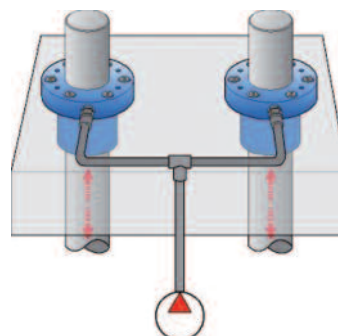
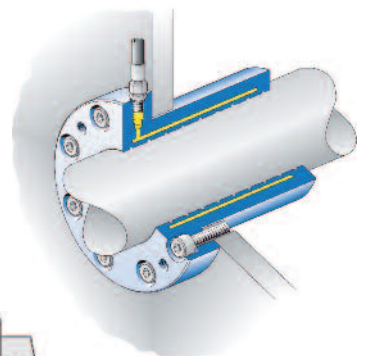

Pressure setting is done with an external pressure source. Several connections can be clamped/loosened simultaneously.

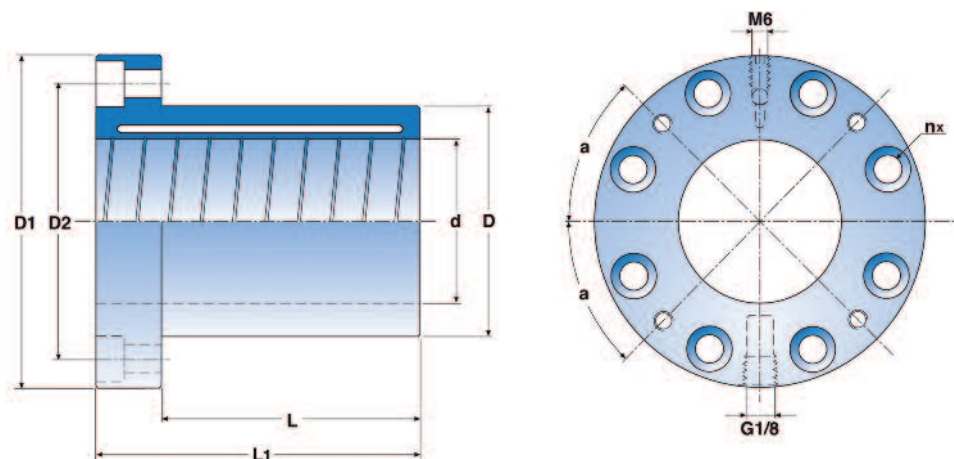

Notation: ETP-OCTOPUS - XX

Technical Specification ETP-OCTOPUS

ETP-OCTOPUS	Dimensions					Transmittable torque or axial force				Screw joint for screw: DIN 912, 12.9				Bore M6 (4 pcs.) for scraper a°	Weight kg
	d mm	D mm	D1 mm	L mm	L1 mm	T1 Nm	T2 Nm	FA1 kN	FA2 kN	n	D2 mm	Dim.	Tt Nm		
● 30	30	42	66	55	75	140	230	9	15	6	52	M6	17	30	0,7
● 35	35	48	72	55	75	180	300	10	17	6	58	M6	17	30	0,8
● 40	40	55	79	55	75	270	420*	13	21	6	65	M6	17	30	1,0
● 45	45	62	86	55	75	370	460*	16	25	6	72	M6	17	30	1,2
● 50	50	70	101	80	100	710	1000	28	42	8	84	M8	40	45	2,0
● 60	60	83	114	100	120	1200	1500*	42	62	8	97	M8	40	45	3,0
● 70	70	97	128	120	140	1700*	1700*	64	92	8	111	M8	40	45	4,6
● 80	80	110	148	130	150	3300	4000*	84	110	10	128	M10	79	54	6,2
● 90	90	125	163	130	150	4100	4400*	91	130	10	143	M10	79	54	8,0
● 100	100	138	176	130	150	4800*	4800*	105	140	10	156	M10	79	54	9,5

T_1 resp. T_2 = transmittable torque when axial force is 0. } At pressure p_1 (350 bar) resp. p_2 (450 bar).
 FA_1 resp. FA_2 = transmittable axial force when torque is 0. }
 *) For these torque values the screw joint sets the upper limit for the torque.
 T_t = recommended tightening torque for the screws.

Dimensions subject to alterations without notice.

● From stock ○ on request

TOLERANCES

Shaft: f7.
Hub: H7 for clearance fit.
N7 for light press fit.
Can also be used without a hub.

OPERATING TEMPERATURE

Depends on the surrounding components within the system (connections/hoses).

PRESSURE MEDIUM

All types of hydraulic oils can be used.

SCRAPER

To prevent abnormal wear of the contact surfaces, the use of a scraper to clean the shaft is recommended. It can be mounted in a ring which is fastened with screws to the flange.

NUMBER OF PRESSURE SETTINGS

The number of cycles mainly depends on the pressure. The following guide values can be used:
 $p = 300$ bar: 500 000 cycles.
 $p = 350$ bar: 300 000 cycles.
 $p = 450$ bar: 100 000 cycles.
 More cycles may cause the sleeve to fatigue.

HYDRAULIC PRESSURE

T and FA changes linearly between the given pressures for a certain shaft size. We do not recommend pressures above 450 bar.

LUBRICATION

The surfaces between ETP-OCTOPUS and the shaft should when moving, create a minimum amount of friction in order to avoid wear, but at the same time when clamping give enough holding force.

This will also be maintained if, as we recommend, the surfaces are reasonably lubricated with mineral oil. The spiral tracks inside the sleeve ensures that any unnecessary amount of lubricant is transferred away. Grease or Molybdenisulfide based lubricants should not be used. We recommend the use of nickel or chrome plated shafts as these are the best from a wear point of view because of reduced friction.

SPECIAL DESIGNS

For models which clamp only to the outside or in both directions there are possible solutions. For such cases please send us information and we will then send a suggestion/quotation.



ETP customized designs

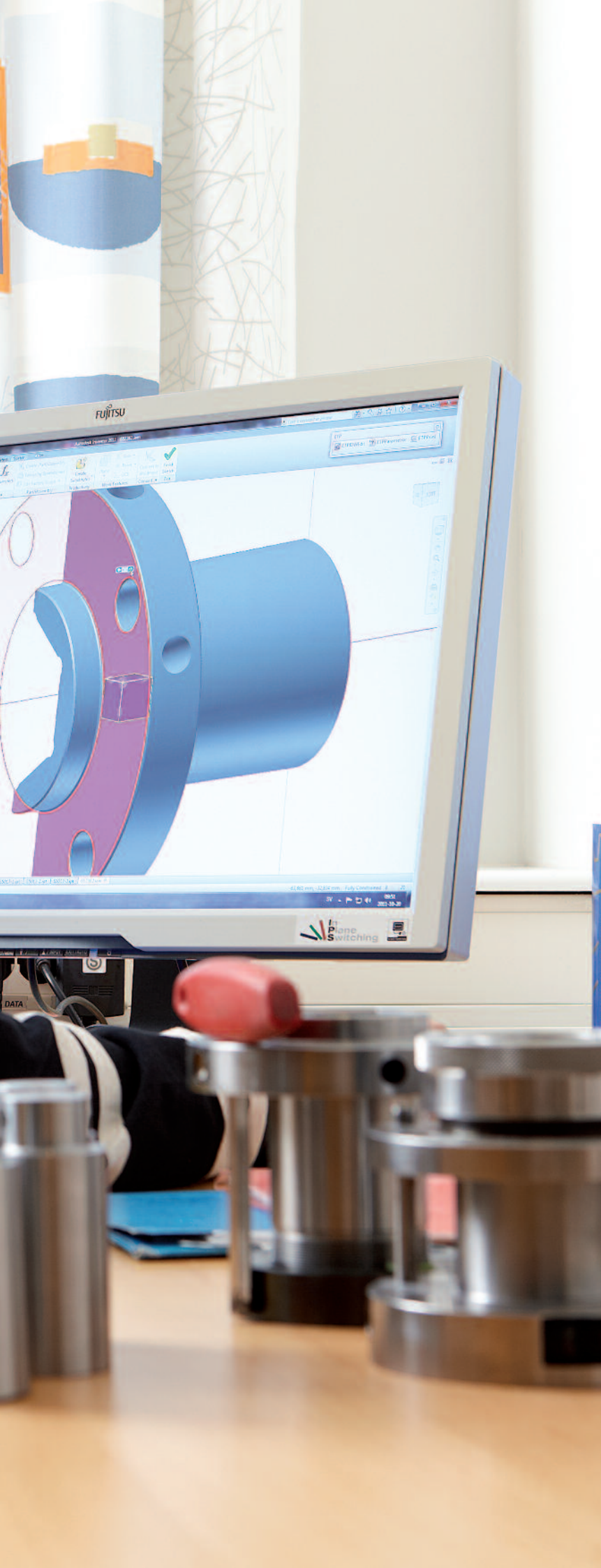

ETP Transmission AB has since its start in the 1970's invented, patented and designed hydraulic and hydromechanical connections for many industries worldwide. Most of them are available as standard catalogue items directly from stock from the ETP-Representatives.

A growing trend on the market is the need among OEM companies for customized designs. Together with our representatives and their technical good knowledge of our products, we develop in close contact between our design & development staff and the corresponding persons at the customer, suitable products according to a jointly agreed "technical specification". On the following pages we will give you some examples of customized ETP-Products.

ETP-AXPRESS®

ETP-AXPRESS (a version of ETP-EXPRESS where the pressure setting is done in the axial direction), is used because of the good and repeatable centering and also for the quick change of decorating cylinders for a new print pattern. This means good quality of the print and increased productivity because of the short downtime.



Optimized design

This customized ETP-AXPRESS fastens and centers the decorating cylinder for printing on the outside of beverage cans.

Decorator for 2 piece beverage cans.

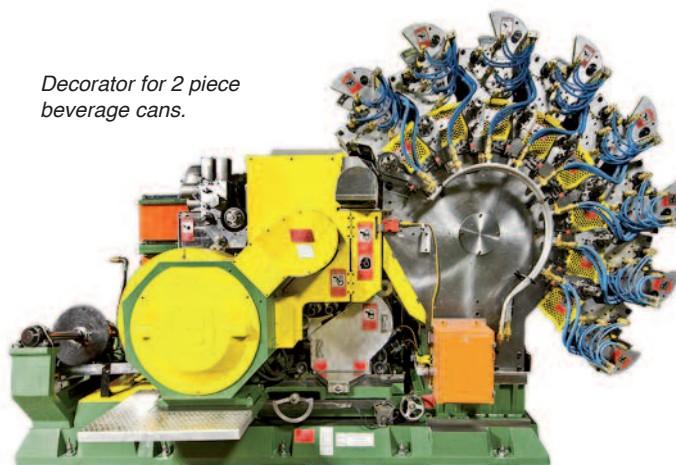

The lever is fastened with ETP-AXPRESS which clamps to the shaft when the screw is tightened. ETP-AXPRESS is locked with a thread to the bore of the lever.

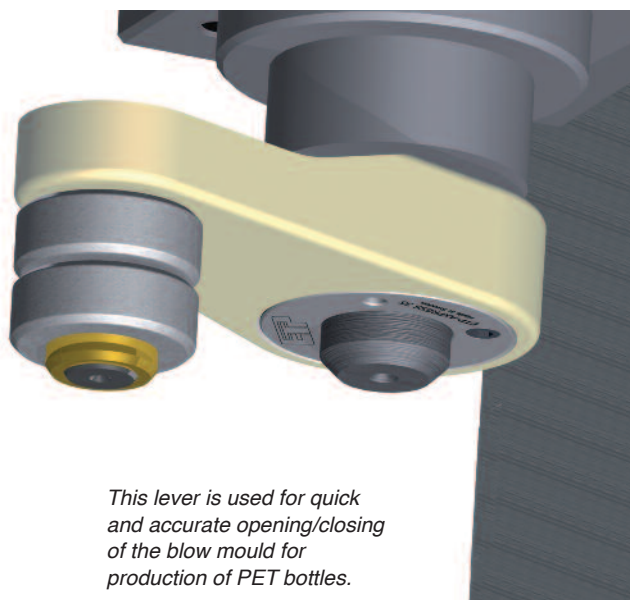

This lever is used for quick and accurate opening/closing of the blow mould for production of PET bottles.

In case of overload ETP-AXPRESS should slip at a certain torque to prevent damages of other parts in the machine.

ETP-AXPRESS has been designed in close co-operation with the machine manufacturer. Some customers tested the ETP solution for a few years, before finally the manufacturer started to use it for new machines.

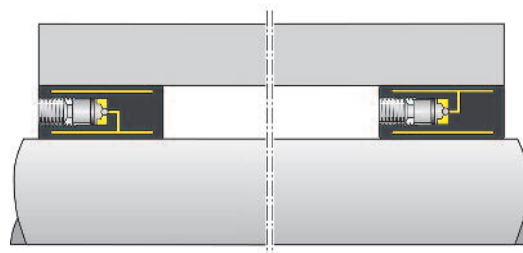
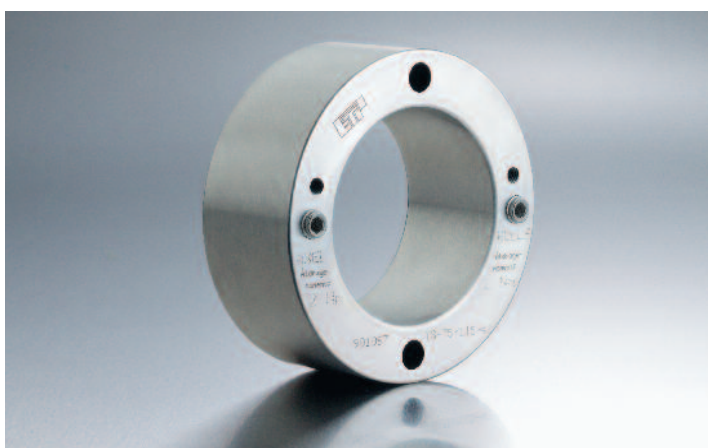

This ETP-AXPRESS is used for fastening and centering of a cylinder in a printing machine for beverage cans of aluminium. It has two separate pressure chambers, one for expansion to the shaft and one to the bore of the cylinder. The runout is better and downtime much shorter than with the mechanical clamping used before



ETP-EXPRESS® custom design

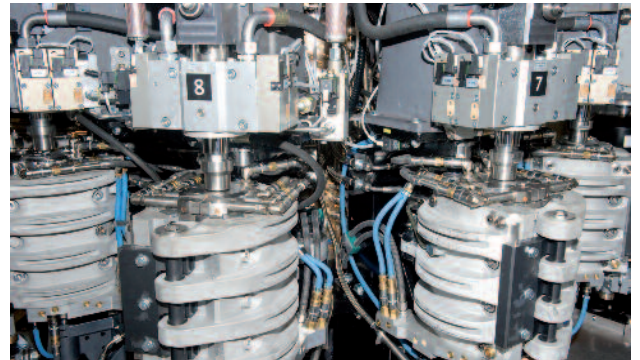

Complete blow mould unit with several moulds/cavities.

This machine manufactures PET bottles. It starts with a small thick walled tube ("pre form"). Each one is fed into one open cavity. The cavity (blow mould) is closed through a lever which is locked with a customized ETP-EXPRESS. After blowing it is taken out of the cavity and moved away for the next operations: filling, labelling, capping and packaging.

ETP-EXPRESS also acts as an overload protection device, in case a bottle gets stuck in the cavity it slips slightly, the machine stops, the operator quickly loosens ETP-EXPRESS, put the cavity into its correct position, tighten the screw in ETP-EXPRESS quickly and start the machine. The customer wanted ETP-EXPRESS to be black to prevent from early corrosion and it also gives it a nicer look.

ETP-EXPRESS reduces the downtime (loss of production) dramatically compared to the mechanical locking device which was used earlier. It also allows for more slippings because the uniform surface pressure is low towards the shaft.

The customer wanted ETP-EXPRESS to slip above a certain torque, otherwise something else in the machine would break. This was achieved through a close development co-operation with the customer, selecting correct shaft size, contact length and tolerances on the mating parts.

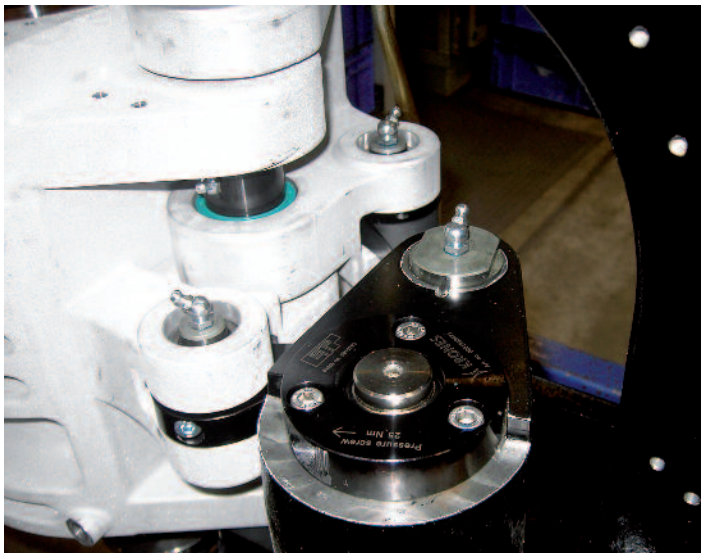

Lever fastened with ETP-EXPRESS to open/close the mould.



ETP-EXPRESS® R custom design

This ETP-EXPRESS R is made of high grade stainless steel, because it is washed regularly with an aggressive cleaning fluid.

It sits in the middle of a rotating in- and outfeed mechanism for PET bottles and stainless arms (which at their ends grips the PET bottles around their necks) are fixed with a shrinkfit into the radial bores of ETP-EXPRESS R.

The complete mechanism has to be moved up or down depending on the size of the bottles. This is easily done by loosening & tightening of a single screw. This ETP-EXPRESS R only clamps to the inside.

Photos courtesy of KRONES AG



ETP-KN®

ETP-KN is designed acc. to the same principle as ETP-TECHNO but the expansion is only against the shaft. It is used for example for fastening of circular knives for slitting thin steelplates when manufacturing beverage and food cans.

The knife is fastened with a nut or with screws onto ETP-KN. ETP-KN gives excellent runout and repeatability as well as fast adjustment. It is only made to customer's specification. Shaft dimensions 50 – 200 mm.

More information can be sent on request.

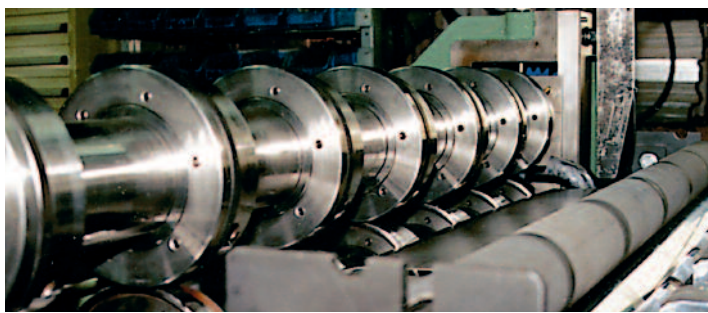
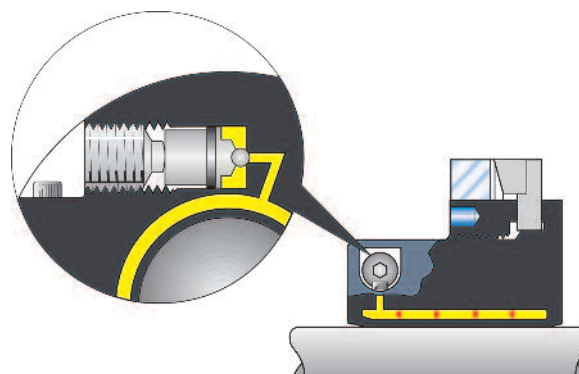

ETP-UNIGRIP®

ETP-UNIGRIP is an axial tensioner for clamping of for example workpieces and tools against a shoulder on the shaft.

ETP-UNIGRIP has two separate hydraulic functions. When tightening the screw, R, ETP-UNIGRIP grips to the shaft. When tightening screw, A, 3 pistons are pressurized which creates a high axial force (20 kN) against the components which are going to be clamped.

ETP-UNIGRIP is available in a limited range of standard sizes for shafts 35 – 65 mm.

More information can be sent on request. Special versions also with threaded inner diameter can be offered.

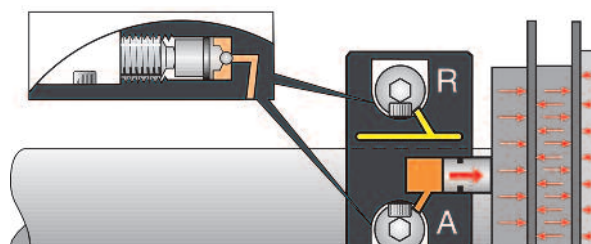

Accessories

ETP-EXPRESS® incl. type R, ETP-TECHNO® and ETP POWER®

Screws

All pressure screws for ETP-TECHNO, ETP-EXPRESS incl. type R and ETP-POWER have cap heads. These are available as spare parts.

Torque wrenches

The torque wrenches are designed for ETP-TECHNO and ETP-EXPRESS incl. type R and ETP-POWER. They are equipped with wratch head and snap function when the fixed torque (recommended tightening torque, T_t) is reached. The hex head key is integrated in a specially designed adapter which facilitates handling and accessibility.

The torque wrenches are specially designed to facilitate the use of the ETP connections and assure a correct tightening.



For size ETP-TECHNO	Torque wrench	Torque (Nm)
15 – 20	M10	10
25 – 32	M16	16
35 – 45	M24	24
50 – 75	M40	40
80 – 110	M60	60
120	M50	50
130	M46	46

Torque wrenches for ETP-TECHNO.

For size ETP-EXPRESS	Torque wrench	Torque (Nm)
15 – 35	M05	5
38 – 60	M21	21
70 – 100	M39	39

Torque wrenches for ETP-EXPRESS incl. type R.

For size ETP-POWER	Torque wrench	Torque (Nm)
15 – 32	M08	8
35 – 40	M25	25

Torque wrenches for ETP-POWER.

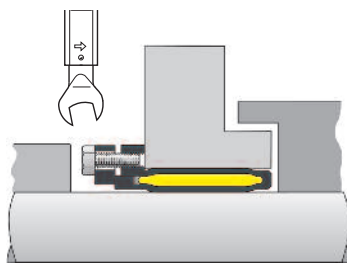

ETP-CLASSIC hex head screws, DIN 933 12.9.
ETP-MINI R hex head screws, DIN 933 A4 (surface coated).

To facilitate the use of the ETP hub-shaft connections there are specially designed torque wrenches, hex head screws and adapters for these.



For size ETP-MINI	Torque wrench	Torque (Nm)	Adapter for hex head
6 – 1/4"	M02	2	–
8 – 14	M04	4	–
R-6	MR1,2	1,2	M-R6*
R-8 – R-14	MR2,7	2,7	A07

Torque wrenches for ETP-MINI incl. type R. *Complete wrench.

ETP-CLASSIC® incl. type R and ETP-MINI® incl. type R

Hex head screws

For ETP-CLASSIC and ETP-MINI R there are hex head screws as accessories. These can be used when space in the axial direction is limited.

Torque wrenches

The torque wrenches have been designed for ETP-CLASSIC and ETP-MINI incl. the R types. They have a fixed torque which releases with a "snap" at the recommended tightening torque, T_t . The torque wrench makes the mounting easier and guarantees a correct tightening.

It is equipped with an adapter which fits the corresponding screws for the ETP connection. For ETP-CLASSIC and ETP-MINI R there is an adapter for hex head screws as accessory, in case the screws have been changed.

For size ETP-CLASSIC	Torque wrench	Torque (Nm)	Adapter for hex head
15	M06	6	A08
19 – 42	M08	8	A08
45 – 65	M13	13	A10
70 – 100	M32	32	A13
R-15 – R-40	MR4,5	4,5	Standard
R-45 – R-50	MR7,8	7,8	Standard

Torque wrenches for ETP-CLASSIC incl. type R.

ETP-HYLOC and ETP-HYCON



Hand pump.
Delivered in a practical steel box.

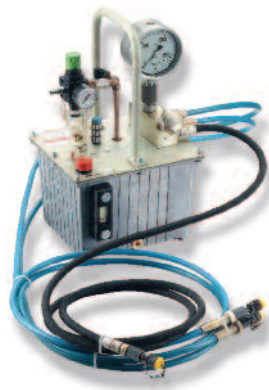

Motor pump.
Pneumatically driven.

Hydraulic pumps

The pumps are designed for easy usage at the pressures and volumes that are needed for ETP-HYLOC and ETP-HYCON.

The handpumps are robust, CE marked, pumps. Motorpumps are designed to be used when mounting frequently.

Both pumps are equipped with manometer and hoses (length 3 m). A threaded connection G 1/8" is on each hose which is suitable for ETP-HYLOC and ETP-HYCON. Threaded connections G1/4" to fit to the quick connections are also included with the pumps.

Max. pressure 1 500 bar, controlled by a pressure release valve. Pressure release valves are available as accessory for 700 and 1000 bar for the handpump.

Pumps for ETP-HYLOC	Type	Pumps for ETP-HYCON	Type
H11	Hand pump	H21	Hand pump
A04	Motor pump	A24	Motor pump

Equipped with 2 high pressure hoses + 1 return hose.

Equipped with 2 high pressure hoses.

Quick connections

When there is a need for fast and frequent mounting, the pumps can be equipped, as accessories, with special high pressure quick connections.

A quick connection consists of one chuck (C), mounted on the pump hose, and one nipple (N), mounted in the pressure connection of ETP-HYLOC or ETP-HYCON.

There are the following 2 versions:

Type 02: the chuck, C-02, is screwed onto the nipple, N-02, with an outer ring.

Type 03: the chuck, C-03 is pressed on to the nipple, N-03. This type has bigger built-in dimensions and can not be used axially, if the shaft pass all the way through, for sizes ≤ 110 mm of ETP-HYLOC.

Quick connection type 02.

Quick connection type 03.



C-02

N-02



C-03

N-03

Friction increasing methods

In certain applications high even loads or high peak loads occur, which could cause the ETP hub-shaft connection to slip. To overcome this problem some ETP accessories have been developed which increases the coefficient of friction, μ , and therefore the transmittable torque and axial force. The enlarged drawings below illustrate the various products. The bore surface of the ETP hub-shaft connection is shown in blue, the shaft in grey.

- **ETP-INTERFIX®** is a specially developed anaerobic adhesive which fills the irregularities in the surfaces. When hardened ETP-INTERFIX forms a layer of approx. 0,002 mm. Content in the bottle: 10 gram. Some premachining of the inner- and outer diameter of the ETP hub-shaft connection is necessary to make sure dismantling is possible.



- **ETP-FRICTION** is a liquid containing extremely small, hard, irregular particles which "grips into" the contact surfaces. It is easily applied with a brush or cloth. ETP-FRICTION will not harden or cure. Content in the can: 125 ml.

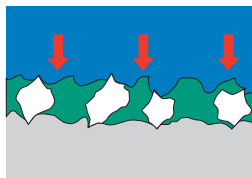

- **ETP-HFC (High Friction Coating)** is a surface treatment of the bore and outside diameter of the ETP hub-shaft connection. ETP-HFC is a carbide coating of small, sharp particles which are imbedded into the treated surface. Is offered separately. Can be done for bore sizes ≥ 100 mm.

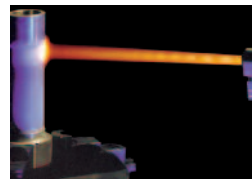
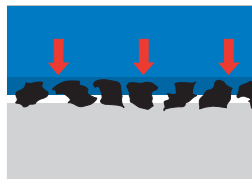

Transmittable torque capacity

Untreated ETP hub-shaft connection = 1 T.

Type of torque	ETP-INTERFIX	ETP-FRICTION	ETP-HFC
Static	2-3 T	2 T	2 T
*Pulsating	2-3 T	Not suitable	Not suitable
*Alternating	2-3 T	Not suitable	Not suitable

*For applications with a large number of load cycles (more than 10 000 times) at an increased torque level, $> T$, there is an increased risk of fatigue in the ETP product. Please contact us to confirm your application.

The friction increasing methods allows for easy dismantling of the ETP hub-shaft connections.

ETP-FRICTION and ETP-INTERFIX must be reapplied after remounting. They have only been tested on ETP hydraulic hub-shaft connections.

Transmittable torque

The ETP connections are tubular and creates a surface pressure on to the shaft and the hub. Through the friction resistance both axial forces and torques can be transmitted. The amount will be determined by the area of the contact length (L_s), the surface pressure and the coefficient of friction (μ).

The following formula is valid: $T = p \cdot \frac{\pi d^2}{2} \cdot L_s \cdot \mu$

L_s = the contact length.

p = surface pressure on the shaft.

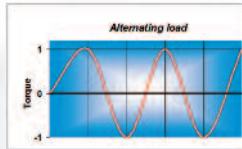
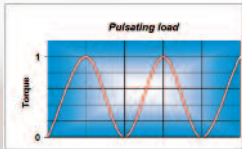

When the loads are in form of alternating or pulsating torque it is recommended to reduce the transmittable torque, T . For further information see technical specification sheet for corresponding product.

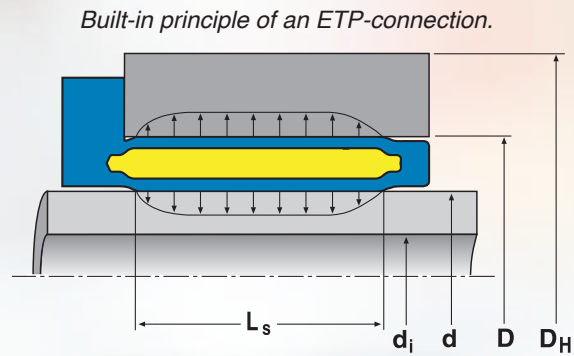

Coefficient of friction (μ)

Recommended surface finish, shaft/hub

R_a max 3,0 (μm)

R_a min 1,0 (μm)

The coefficient of friction depend on a number of factors. The most important are:

SURFACE FINISH

The surface must not be too smooth. If it is, the influence of impurities can be big. A good turning operation is often better than grinding.

CLEANLINESS

It is very important that the surfaces are well cleaned. Grease on the surfaces will drastically reduce the coefficient of friction. A thin oil will however only reduce the coefficient of friction with about 0,03 μ .

Surface pressure

If the surface pressure is too low, a metallic contact between the surfaces will not be created because of oxide layers. If the surface pressure is too high, plastic deformation can occur and the friction will decrease dramatically. The hydraulic ETP principle gives a surface pressure within the right range, which is also even around and along the contact area.

The surface pressure from the ETP connections (not ETP-HYLOC) is at the recommended tightening torque approx. 80 N/mm².

Runout and balance

The hydraulic ETP principle assures a good runout and balance. All products are balanced by design. For guide values see the table.

To these values the runout/unbalance for shaft and hub in the actual case has to be added, in order to get the final value when mounted.

Balancing can be done on request.

ETP-EXPRESS and ETP-TECHNO can be dynamically balanced to G 2,5, at a specific rpm, on request.



Design tip

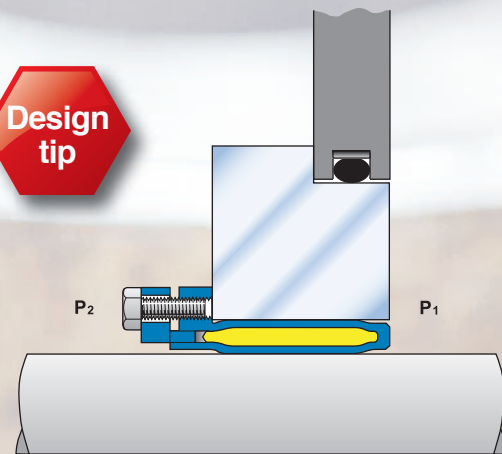

At varying temperature and with a hub made from aluminium ETP-connections can be used. Because of the even surface pressure and the lack of slotted sleeves, ETP-connections can function as a sealing element up to a pressure difference, $p_1 - p_2$, of 50 bar.



Design tip

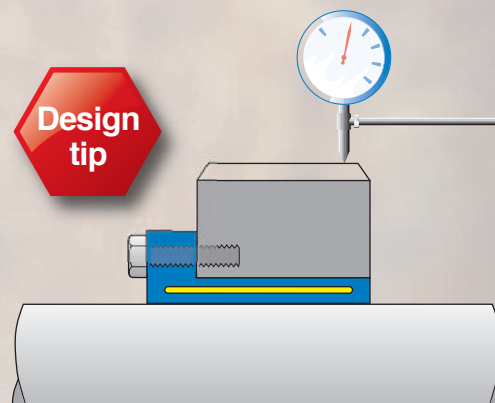

When manufacturing precision gears, they can be fastened with ETP- EXPRESS. If the gear is fixed in its position with an axial screw or pin before the last grinding operation, a repeatability within 2 μm will be achieved.

	ETP-EXPRESS incl. type R	ETP-TECHNO	ETP-POWER	ETP-CLASSIC incl. type R	ETP-MINI incl. type R	ETP-HYLOC
Runout (mm)*	≤ 0,02	≤ 0,006	≤ 0,03	0,03 – 0,06	≤ 0,02	≤ 0,02
Unbalance (gmm/kg)	75	50	75	100	100	75**

* Values are also valid after repeated mountings.

** For size ≤ 100 mm, with radial mounted steel plugs, the unbalance is larger.

Dimensioning of hubs and hollow shafts

Because of the even and reasonable surface pressure and the compact built-in dimensions of the ETP connections, a thin material in hub and shaft can be used. Also aluminium is possible.

For hubs and hollow shafts in steel, the yield point of those decides the thickness of the material. For cast iron and aluminium the module of elasticity is decisive. The requisite thickness can be selected from the table or more accurately in the diagram.

For ETP-HYLOC and ETP-OCTOPUS see information under the corresponding product section, the information below is not valid for these.

R_{eL} = Yield point for the material.

E = Module of elasticity.

D_H = The minimum outer diameter of the hub.

d_i = The maximum inner diameter of the hollow shaft.

For other notations see figure on page 52.

If $D_H/D < 1,4$ for the hub or if $d_i/d > 0,6$ for the hollow shaft, contact us for advice.

For all materials there will be an elastic expansion/compression of the hub/hollow shaft.

The expansion/compression will not be uniform of the hub/hollow shaft if the material is unsymmetrical.

For accurate calculation contact us.

HUB

Material	D_H/D
Steel incl. stainless, $R_{eL} > 300 \text{ N/mm}^2$	1,4
Steel incl. stainless, $R_{eL} > 220 \text{ N/mm}^2$	1,5
Cast iron, $E=120 \text{ kN/mm}^2$	2,0
Aluminium, $E=70 \text{ kN/mm}^2$	2,5

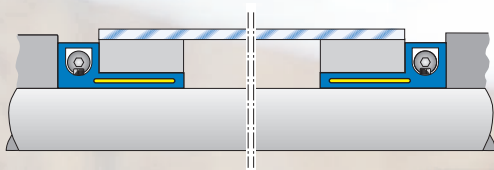
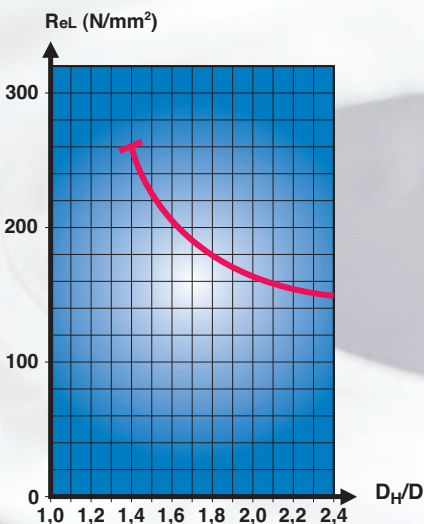

HOLLOW SHAFT

Material	d_i/d
Steel incl. stainless, $R_{eL} > 300 \text{ N/mm}^2$	0,6
Steel incl. stainless, $R_{eL} > 240 \text{ N/mm}^2$	0,5
Cast iron, $E=120 \text{ kN/mm}^2$	0,3
Aluminium, $E=70 \text{ kN/mm}^2$	0,2

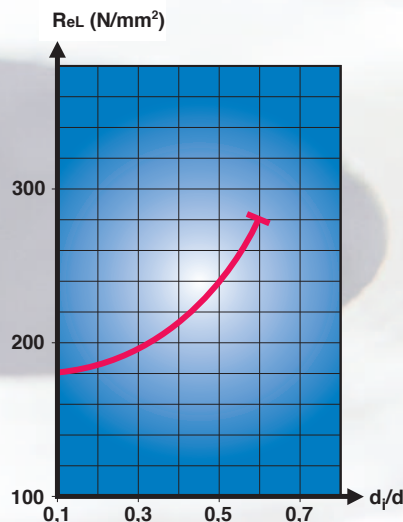

ETP-TECHNO gives advantages when used to fasten printing cylinders in light materials for example aluminium. The cylinder can be changed 1000's of times, using the same ETP-TECHNO, with maintained good concentricity and repeatability. The radial access to the screw facilitates the handling and saves space.

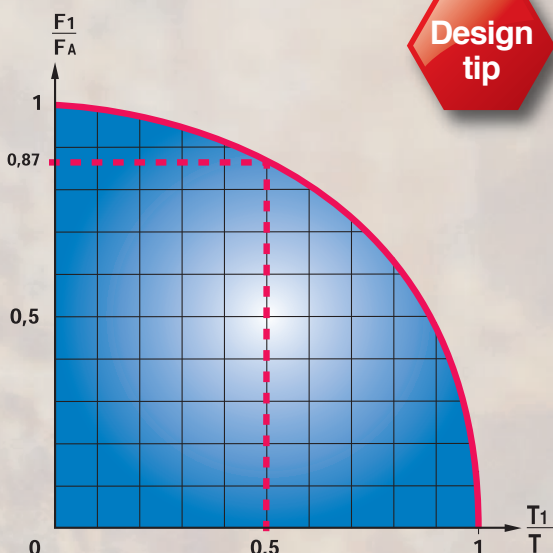

Get the most out of your hub-shaft connections

- Download our ETP Calc App

See page 6.



Axial force

If an axial force (F_1) and a torque (T_1) are to be transmitted at the same time, the following formula is valid.

$$\left(\frac{F_1}{F_A}\right)^2 + \left(\frac{T_1}{T}\right)^2 \leq 1$$

this means that the value should be inside the quarter circle in the diagram.

F_A and T are the rated values for axial force and torque for the different ETP products.

Number of mountings

ETP connection	Nbr. of mountings
ETP-EXPRESS 15-35	2000
ETP-EXPRESS 38-65	1000
ETP-EXPRESS 70-100	500
ETP-EXPRESS R 15-35	800
ETP-EXPRESS R 38-60	400
ETP-EXPRESS R 70-80	200
ETP-TECHNO 15-45	5000
ETP-TECHNO 50-75	3000
ETP-TECHNO 80-130	500
ETP-POWER 15-30	500
ETP-POWER 32-1 3/4"	200
ETP-CLASSIC	100
ETP-CLASSIC R	50
ETP-MINI	100
ETP-MINI R	50
ETP-HYLOC	2000
ETP-OCTOPUS	100 000 - 500 000

One of the qualities with the ETP connections are their ability to be mounted quickly and repeatedly with maintained performance and precision.

There is however a limit when the screw/screws will be worn and has to be changed. If the threads are cleaned and regularly lubricated, the guide values in the table can be used.

The values indicates when the screw needs to be changed, the ETP connection lasts longer.

For the R types it is very important that the screws are well lubricated when tightening, both for proper function and full lifetime capabilities. When used in food processing applications or similar we recommend the lubricant Molykote P-1900. For other applications Molykote G-n plus can be used.

ETP-HYLOC is not recommended for more than 2000 mountings.

Radial loads and bending torque

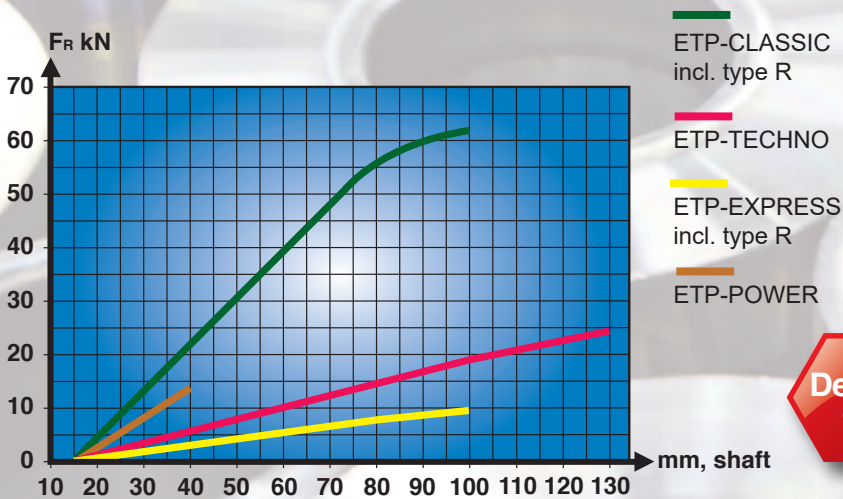

Radial force – shaft size.

Most friction joints have limited capacity to transmit radial forces and bending torque. High levels of these loads can affect the function of the ETP connection. The values acc. to the diagram and table based on tests can serve as guide lines. ETP-MINI and ETP-HYLOC can transmit essentially higher radial forces than the other connections.

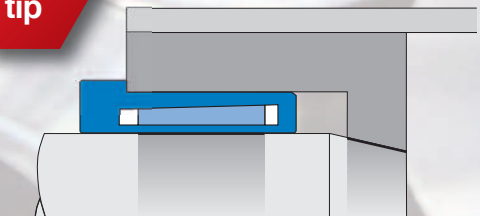

Long thin rollers subjected to high bending torque, can be fastened to stub shafts with ETP-HYLOC. To decrease the elastic deformation of the roller and make it easier to take up the bending torque, the inner part of the hub and the stub shaft can be designed with conical support surfaces. ETP-HYLOC gives good concentricity and fast changes.

	ETP-EXPRESS incl. type R	ETP-TECHNO	ETP-POWER	ETP-CLASSIC incl. type R	ETP-MINI incl. type R	ETP-HYLOC
Bending torque as % of transmittable torque, T.	5	10	10	15	30	15

Temperature

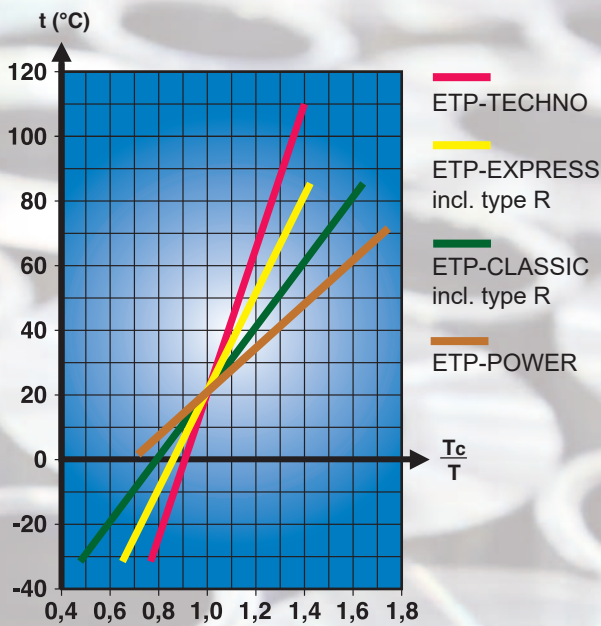

The pressure medium in hydraulic ETP connections and the double-walled steel sleeve have different volume expansion coefficients. This means that when the temperature rises, the pressure in the connection increases and a higher torque can be transmitted. The opposite is valid at decreasing temperature. Also the seals built into the connections decides the upper and lower operating temperatures.

The following has to be taken into consideration when the operating temperature differs from the mounting temperature:

- Max. and min. temperature for continuous operation, see table. ETP-MINI and ETP-HYLOC can withstand essentially wider upper and lower limits.
- The decrease in torque due to lower operating temperatures, see diagram. ETP-MINI and ETP-HYLOC are not affected.

T = transmittable torque acc. to technical data.

T_c = transmittable torque at operating temperature.

ETP connection	Min. temp. °C	Max. temp. °C
ETP-EXPRESS incl. type R	- 30	+ 85
ETP-TECHNO	- 30	+ 110
ETP-CLASSIC incl. type R	- 30	+ 85
ETP-POWER	0	+ 70

Torque and speed

Due to centrifugal force, the transmittable torque will be reduced with increasing speed (rpm). The diagram gives examples for ETP-TECHNO 50 with a steel hub. A reduced tolerance between the contact surfaces gives a higher surface pressure at the same tightening torque, and thus higher transmittable torque at high speeds. A thicker hub is more effected by the centrifugal force and the torque will reduce faster at increasing speed. The example is not directly applicable for other sizes or types of ETP connections. Contact us for assistance with calculations at high speeds.

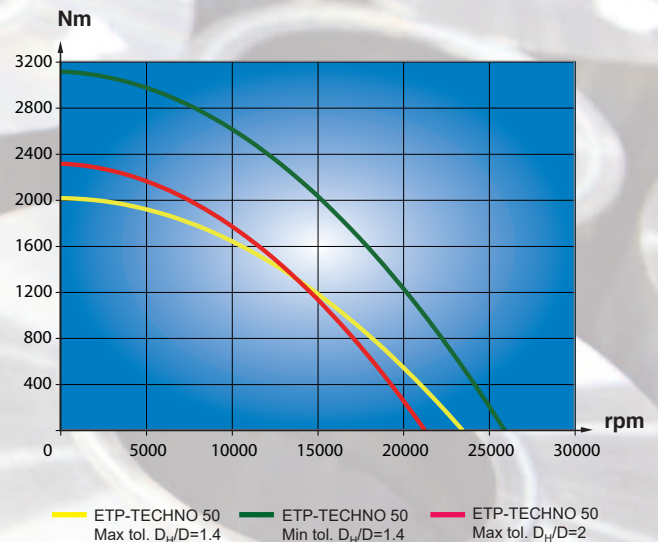

Keyways

If there is a keyway in the shaft or hub, we recommend it to be filled in with for example some two component hardening medium (not needed for ETP-MINI). The medium is then hand ground to the approximate diameter of the shaft/hub. This prevents deformation and dismantling problems of the double-walled sleeve.

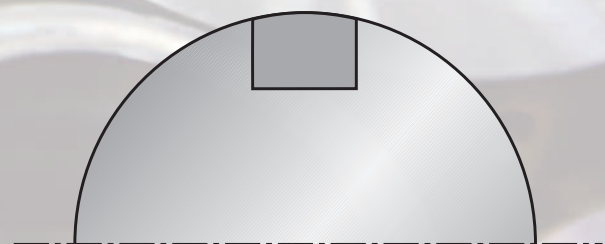



Box 1120, SE-581 11 Linköping, Schweden
Tel. +46(0)13247100,
E-mail: info@etp.se, Internet: www.etp.se